

S-CAN 3D Ltd.

Unit 10b,
Bunn's Bank Ind Est,
Attleborough
Norfolk, UK
NR17 1QD

Tel: +44 (0)1953 857800
Email: info@atpowerthrottles.com
Web: www.atpower.com



Wabash 971 RPS

Rotary Position Sensor

Designed to operate in demanding environments where long life and high performance is required.

The Wabash 971 Rotary Position Sensor (RPS) uses high performance conductive polymer tracks and contact designs to achieve 2 percent independent linearity. Reliable and versatile, it is ideal for applications such as:

- Electric industrial vehicles
- Off-road steering and transmission
- Engine management and controls
- Recreational vehicles
- Agricultural equipment

The RPS can be supplied with options for electrical track length, resistance, flying leads, integral connector and actuator drive direction. Its rugged design can withstand:

- Temperature extremes
- Harsh environments
- Mechanical shock and vibration

Technical Specifications

PHYSICAL

- Fully “sealed” robust package suitable for automotive, agricultural, marine and industrial environments
- High performance, compact potentiometric sensor
- Suitable for arduous engine management and closed loop control system feedback applications
- Through-hole actuation capability
- Integral connector or flying lead versions
- Actuator and mounting configuration options

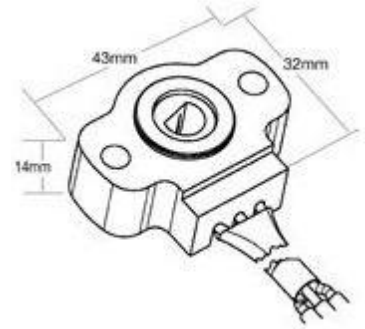

ELECTRICAL

	Specifications
Track Resistance (Rt)	5KΩ ±20% @ 20°C ±10°C
Linearity (Independent)	±2%
Index Point	3% ±2% @ -Low End Stop
Output Gradient	0.973%/° Max 0.873%/° Min
Power Rating	1 Watt @ 40°C Derated to Zero @ 135°C
Temperature Coefficient	±600ppm/°C
Insulation Resistance	1000MΩ Min 500V DC
Maximum Voltage	13.5V DC

MECHANICAL

	Specifications
Rotation	128° ±2°
Spring Torque	Min Return - 6 Nm Max Wind up - 120 Nm
Mechanical End Stop Strength	680Nmm Min
Fixing Torque (M4 and Washer)	2Nm Maximum
Lead Wire Version 971 - 0002	16/0.2, 0.5 mm CSA 1.8 mm OD
Connector Version 971 - 0001	Pull Strength: 10 kg Max (all 3 wires) Connector to M47/2 AMP P/N 828748 - 3

PERFORMANCE & ENVIRONMENTAL

	Specifications
Rotation Life (- 40° - +130°C)	5, 000, 000 Full Cycles 10, 800, 000 Dither Cycles (2°)
Functional Temperature Range	-40°C to +85°C Wire Version -40°C to +155°C Connector Version
Mechanical Shock (Handling)	1m Drop onto Concrete Floor
Mechanical Shock (Bump)	1000 40 g 11 ms Shocks (3 axis)
Vibration (Sinusoidal)	10 - 57 Hz @ 1 mm Displacement 57 - 100 Hz @ 10 g 100 - 500 Hz @ 27 g
Sealing	IP 5X (dust)
Pressure Wash	90 Bar 0.5-0.6 m 5-6 Seconds
Humidity	40°C 96% RH 504 Hours
Chemical Resistance	Screen Wash, Gearbox Oil Brake Fluid Dot 4 Isotane/Toluene (70/30) + 15% Methanol Engine Cleaning Agent, Engine Coolant Antigel Fluid, Electrolyte Density 1285 Kg/m3 (Sulphuric Acid H2SO4)

We reserve the right to modify this file's content or make technical changes without notice. For purchase orders, agreed terms take precedence. S-CAN 3D Ltd. accepts no liability for errors or omissions in this document.

Copyright Notice © S-CAN 3D Ltd.