

**S-CAN 3D Ltd.**

Unit 10b,  
Bunn's Bank Ind Est,  
Attleborough  
Norfolk, UK  
NR17 1QD

Tel: +44 (0)1953 857800  
Email: [info@atpowerthrottles.com](mailto:info@atpowerthrottles.com)  
Web: [www.atpower.com](http://www.atpower.com)



## Magneti Marelli Type (PF1C/PF2C) Throttle position sensor

Sealed, Spring Return Rotor  
Clockwise or CounterClockwise Rotation Available  
Tin Plated Terminals

Pin information  
A – Ground  
B – 5v Supply  
C – Signal

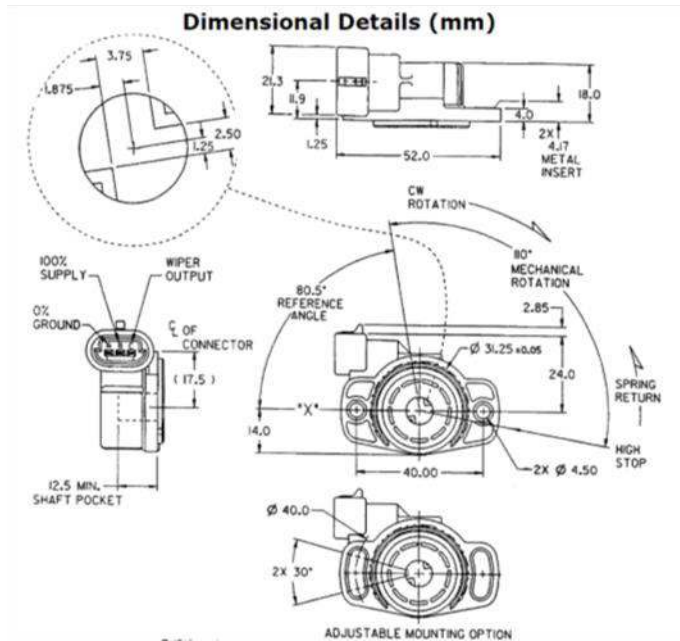

### Ordering information

101-130-00013 - Output D-Shaft drive orientation is 'Anti-Clockwise' when viewed from the mounting face of the sensor.  
101-130-00014 - Output D-Shaft drive orientation is 'Clockwise' when viewed from the mounting face of the sensor.

### ELECTRICAL/MECHANICAL

Total Resistance: 1.2 K $\Omega$   $\pm$ 30%  
Linearity:  $\pm$ 3.0% (absolute)  
Rotation Max: 110 Mechanical  
107 Typ. Electrical  
Hysteresis:  $\leq$ 1.0% Applied Voltage  
Electrical Limit: 16 VDC Maximum  
Typ. Voltage: 5-10VDC  
Max Power Rating: 0.08 Watts  
Torque – Start of rotation:  $>$ 0.020Nm  
End of rotation:  $<$ 0.120Nm  
Stop Strength: 0.6Nm

### DURABILITY/ENVIRONMENTAL

Mechanical Cycling: 1 x 10<sup>6</sup> Full Strokes  
0.5 x 10<sup>6</sup> Half Strokes  
4 x 10<sup>6</sup> Dither Strokes  
Standard Vibration: 24 hrs; 3 Planes;  
33 – 600Hz; 3 – 25g  
Thermal Shock: 100 Cycles, -40 to 140  
Temp Range (Operating & Storage) -30 to 125 C  
Salt Spray: 250hrs  
Humidity: 96hrs, 93% RH at 40 C  
Resistant to gasoline, engine oil, brake fluid & antifreeze

The above specification has been met on existing production tooled units. However, it does not constitute a warranty that the product will meet the above specifications in your application.

We reserve the right to modify this file's content or make technical changes without notice. For purchase orders, agreed terms take precedence. S-CAN 3D Ltd. accepts no liability for errors or omissions in this document.

Copyright Notice © S-CAN 3D Ltd.