



L-Belt Installation Guide

Read thoroughly before installing any AT Power products.

Designed and manufactured in-house in the UK.

Timing Belt Tensioning

Unsure what timing belt length you need? Simply wrap a piece of string around the pulleys, lay it flat, and measure it - this will give you the required L-Belt length. For compatible timing belts, please visit our website. For correct tensioning procedures, refer carefully to the following pages.

Proper timing belt tension is critical. Insufficient tension can cause the belt to ratchet (skip teeth). A loosely tensioned belt behaves like a slack string, which can snap under high torque as the excessive stress surpasses its design limits.

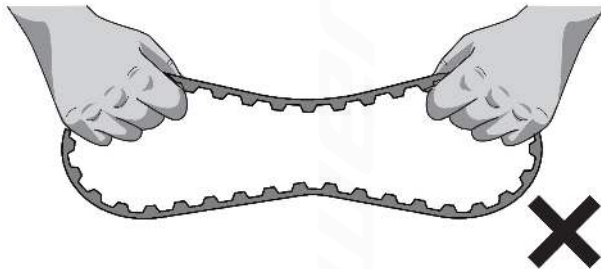

Excessive tension may lead to premature wear or damage to bearings, shafts, and other drive components, significantly reducing the belt's lifespan.

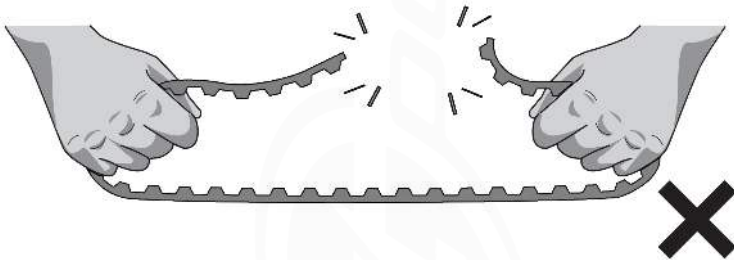

In contrast, a properly tensioned belt, like a taut string, can withstand strong forces without failure. The ideal tension is the lowest possible tension that allows the belt to transmit the required mechanical power without skipping teeth under full load:

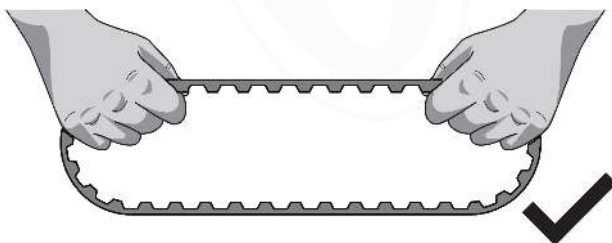

Timing Belt Installation

Ensure the pulleys are properly aligned both parallel and angularly for smooth operation - if they're misaligned, the timing belt may slip off or come loose during use.

Carefully inspect the timing belt for any signs of damage. If there is damage, do not proceed with the installation.

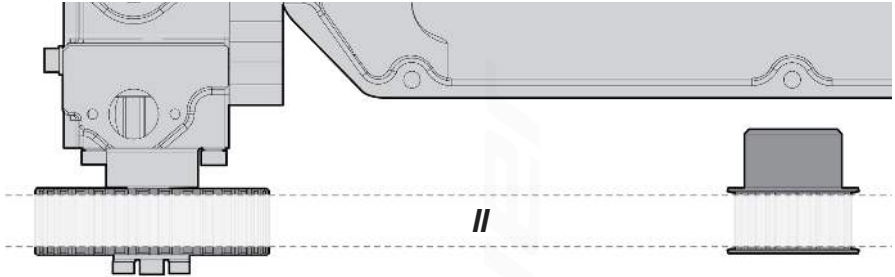

To install and properly tension the timing belt, begin by reducing the centre distance (A) between the pulleys or releasing the tensioning idler to allow for easy belt placement.

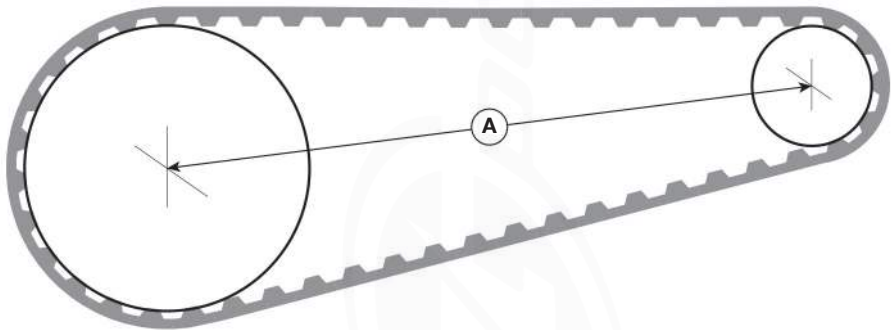

Carefully position the belt onto the pulley, ensuring that the teeth are fully seated in the pulley grooves - do not pry the belt onto the pulleys, this can cause damage.

Once the belt is in place, increase the centre distance (A) or adjust the tensioning idler to remove any slack. Before applying final tension, manually rotate the drive system to confirm the belt teeth remain properly engaged in the grooves.

After the pre-tensioning steps are complete, there are several methods for verifying proper final tension.

Numerical Method For Belt Force/Deflection

The numerical method involves measuring the deflection of the timing belt under a known force to achieve the required tension. The target tension is determined by two key values: Deflection Force and Deflection Distance.

Timing Belt Tensioning Procedure

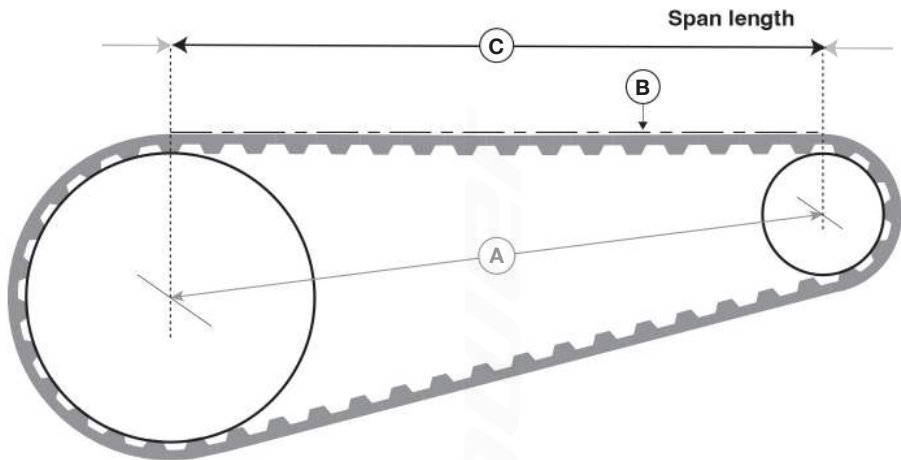

Lay a straight edge (B) across the top of the timing belt.

Use this calculation to work out the required deflection distance:

$$\frac{1}{64} \times \text{Span Length (C)} = \text{Deflection (D)}$$

Measured from Pulley Centres

Pencil-Style Tension Gauge

Set the large O-ring on the pencil-style tension gauge (pictured) to the Deflection (D) measurement above.

Set the small O-ring on the plunger to zero (E). This measures the Deflection Force in pounds (lbs).

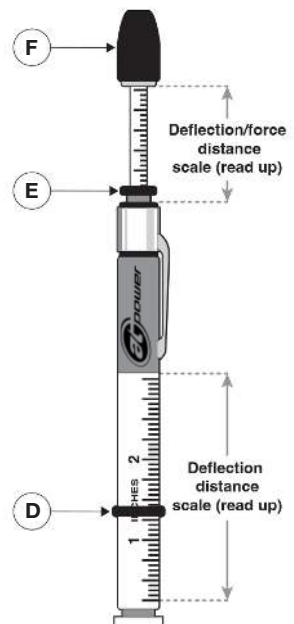

At the centre of the span length (C), apply force using a pencil-style tension gauge, ensuring the force is applied perpendicular to the span with the rubber plunger (F) pressed against your palm.

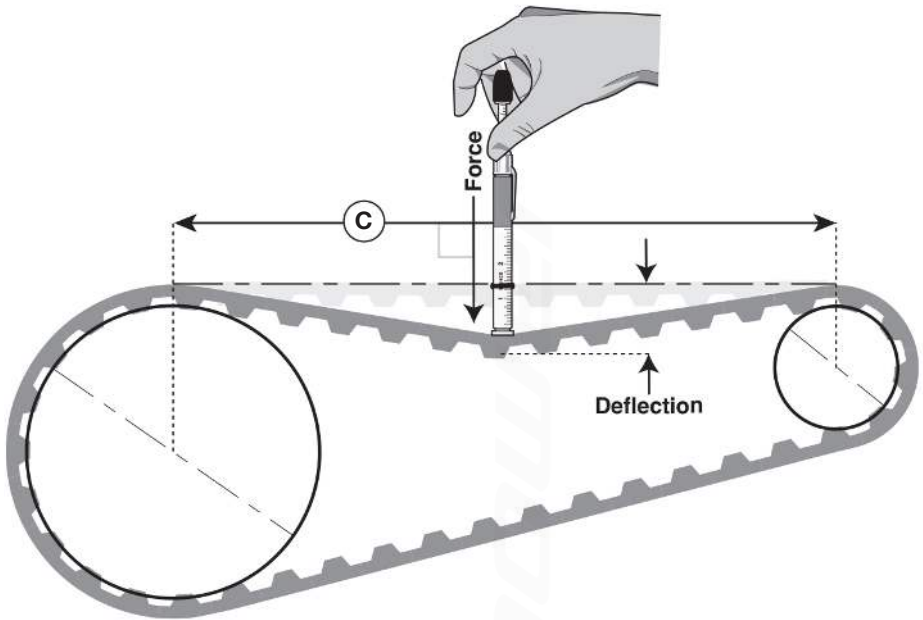

Deflect the belt until the bottom of the large O-ring (D) is level with the bottom of the straight edge. Release the pressure and note the deflection force indicated by the small O-ring (E).

Identify the correct deflection force required in this grid to achieve proper belt tension.

Belt	Width	Deflection Force
'L' section 3/8" pitch	1/2"	7oz 198g
	3/4"	11oz 312g
	1"	1lb 397g

For adjusting, see next page.

Timing Belt Final Adjustments

After these pre-tensioning steps, several methods can be used to verify that the final tension is correct. If the measured force is less than the required deflection force, increase the centre distance (A) to add tension.

If the measured force is greater than the required deflection force, reduce the centre distance to relieve tension.

After properly tensioning the timing belt, secure the centre distance adjustments and verify that the sprockets remain correctly aligned.

After approximately eight hours of operation, recheck both the timing belt tension and sprocket alignment to ensure the drive has not shifted.

AT Power Belt Driven Dry Sump Kits

For all belt-driven dry sump kits produced by AT Power that do not include a belt tensioning facility, 4 x M6 flat washers (F) can be added between the oil pump and the mounting bracket to achieve the required belt tension, if necessary.

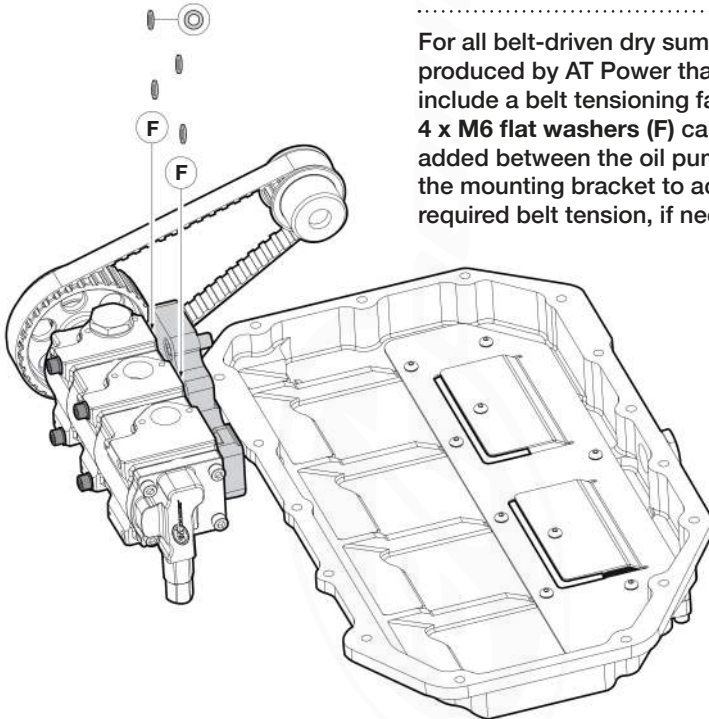

Following this procedure ensures optimal timing belt tension, maximising performance and longevity.



Tag us in your engine build!



Connect via WhatsApp

www.atpower.com

Tel: +44 1953 875800

info@atpowerthrottles.com

**S-CAN 3D Ltd, Unit 10b Bunns Bank Ind Est,
Attleborough, Norfolk, NR17 1QD, United Kingdom**

