

MEGAFLOW AIR FILTER SOLD SEPARATELY
 JC50/S/65
 PART: 102-108-0039

SELECT RIGHT SIDE TPS
 WABASH PICTURED

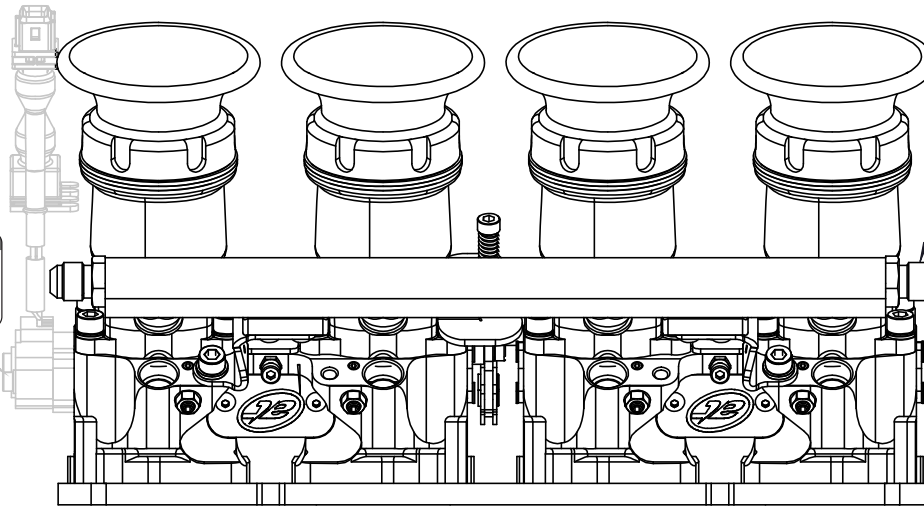
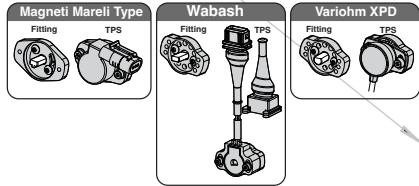

JIC-6 AN6 FITTING
 BOTH ENDS

RHS

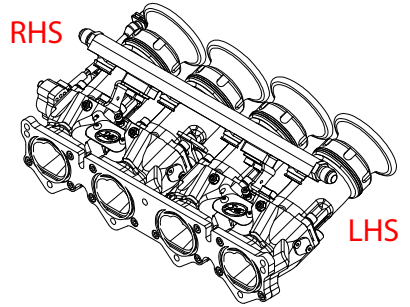

LHS

LEFT SIDE

RIGHT SIDE

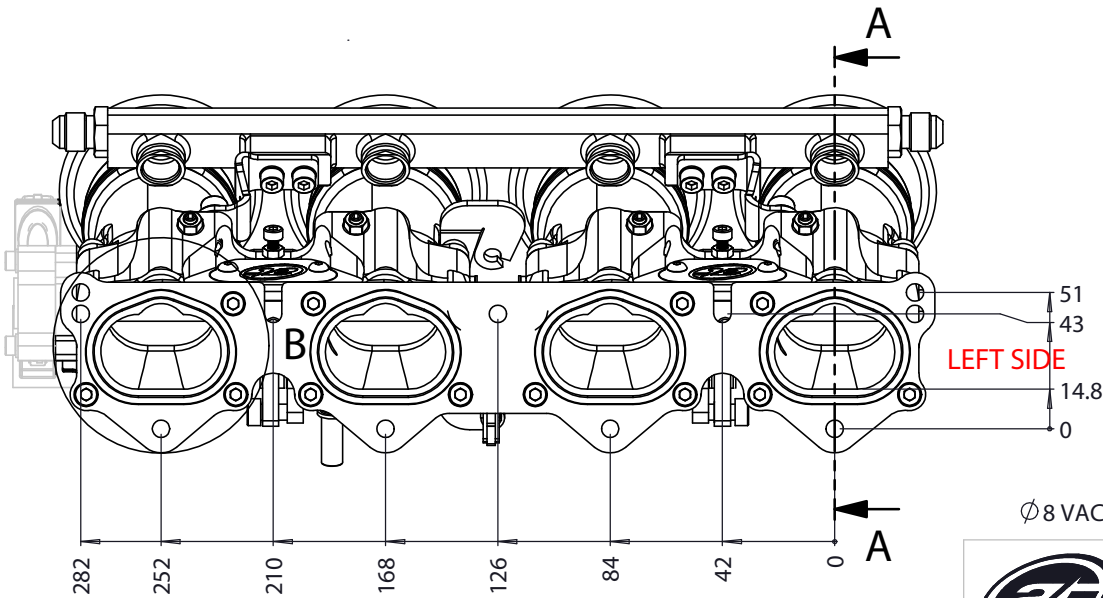

LEFT SIDE

INJECTOR BRACKET SUITABLE
 FOR PICO INJECTORS

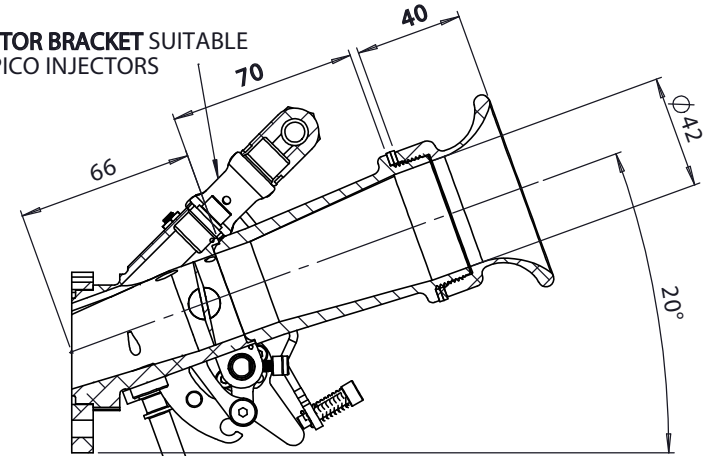

Ø8 VACUUM TAKE OFF

SECTION A-A

DETAIL B

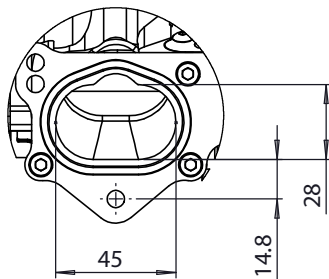

S-CAN 3D Ltd
 Bunn's Bank Ind Est
 Attleborough NR17 1QD

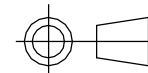

THIRD ANGLE PROJECTION

SCALE 1:2 WEIGHT 2447.305 kg

DRAWN - S.HOW

DATE - 10/07/25

CHECKED - S.HOW

APPROVED - S.HOW

UNLESS OTHERWISE STATED:
 DIMENSIONS IN MILLIMETRES
 TOLERANCES: LINEAR ±0.1 ANGULAR ±0.5°
 SURFACE FINISH √ = √
 DRAWING STANDARDS TO ATQS 6003
 DATE FORMAT: DD/MM/YY
 THIS DESIGN IS THE PROPERTY OF
 S-CAN 3D LTD AND MUST NOT BE
 REPRODUCED OR COMMUNICATED
 WITHOUT AUTHORITY

CAD PLOT
 DO NOT
 SCALE

MATERIAL

SEE COMPONENT PARTS

FINISH

SEE COMPONENT PARTS

DRAWING TITLE

ASSY - HOUSING - TWIN -
 PEUGEOT/CITROEN - TU5JP4
 ENGINE - PRE-CONFIGURED

DRAWING NUMBER

102-102-00582