

Ensure sizes fit in engine

Available Trumpets:

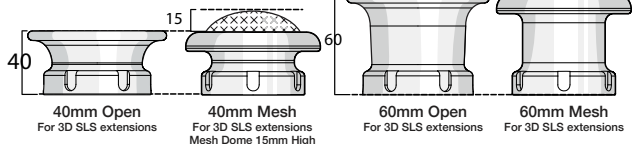

Available Extension Lengths: Contact us for curved

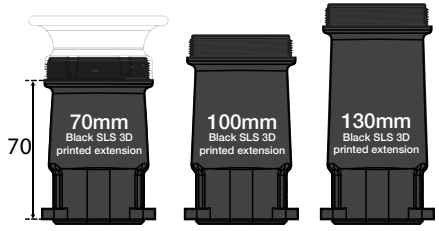

Available TPS Sides and TPS Options

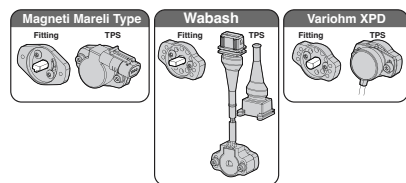

Available Fuel Injector Mounting Brackets:

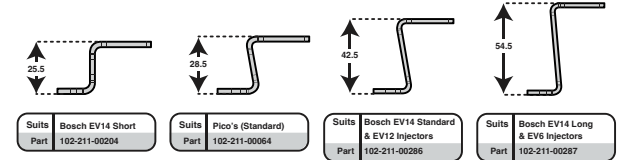

Available Fuel Rail End Fittings:

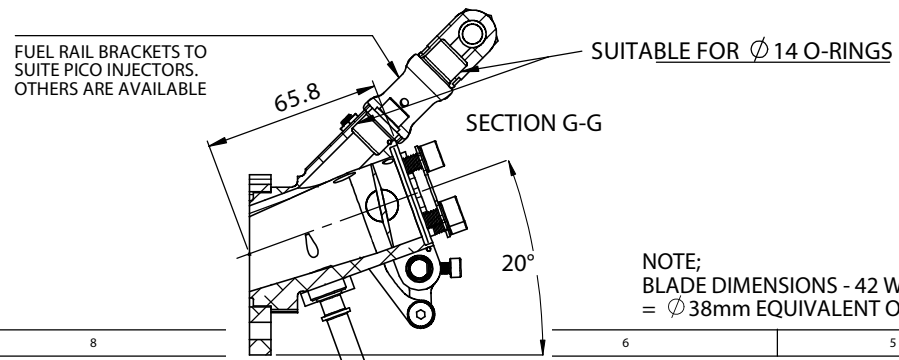

NOTE;
BLADE DIMENSIONS - 42 WIDE x 36 HIGH
= \varnothing 38mm EQUIVALENT OVAL

<p>S-CAN 3D Ltd Bunns Bank Ind Est Attleborough NR17 1QD</p>	<p>THIRD ANGLE PROJECTION</p>		MATERIAL	SEE COMPONENT PARTS
	SCALE 1:2	WEIGHT 1.7 kg	FINISH	SEE COMPONENT PARTS
<p>UNLESS OTHERWISE STATED: DIMENSIONS IN MILLIMETRES TOLERANCES: LINEAR ± 0.1 ANGULAR $\pm 0.5^\circ$ SURFACE FINISH $\sqrt{}$ = $\sqrt{}$ DRAWING STANDARDS TO ATQS 6003 DATE FORMAT: DD/MM/YY</p> <p>THIS DESIGN IS THE PROPERTY OF S-CAN 3D LTD AND MUST NOT BE REPRODUCED OR COMMUNICATED WITHOUT AUTHORITY</p>	DRAWN-	S.HOW	DRAWING TITLE	ASSY - HOUSING - TWIN - PEUGEOT/CITROEN - 106-SAXO (TUJ4/TUJP4 & 206-C2 (TU5JP4)
	DATE-	13/07/22	DRAWING NUMBER	102-104-00022
	CHECKED-	S.HOW		
APPROVED-	S.HOW	CAD PLOT NOT SCALE		

Select Cable Pull or Drive-By-Wire

Cable Pull Linkage

All Linkage suitable for AT Power's 3m Motorsport Throttle Nipple Cable (Sold Separately)

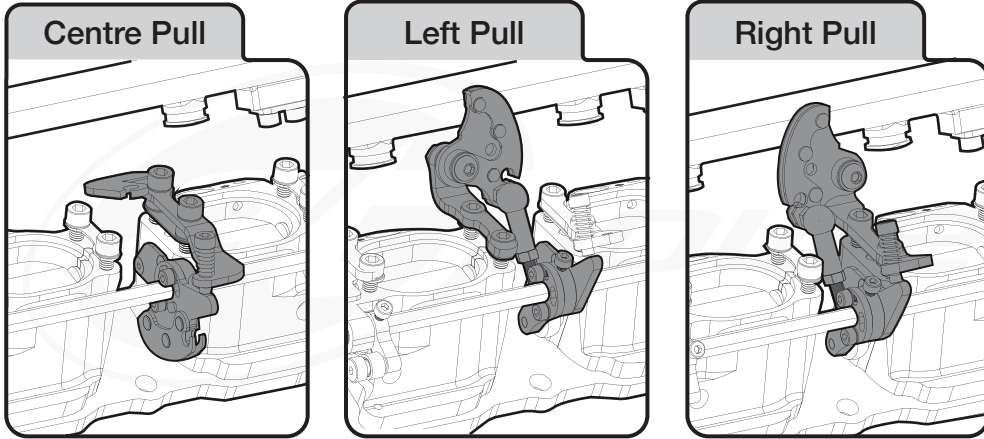

DBW (Drive-By-Wire) Actuator Mounting

If you have selected DBW, in the drop down box please advise Mounting Bracketry type:

MOUNT:

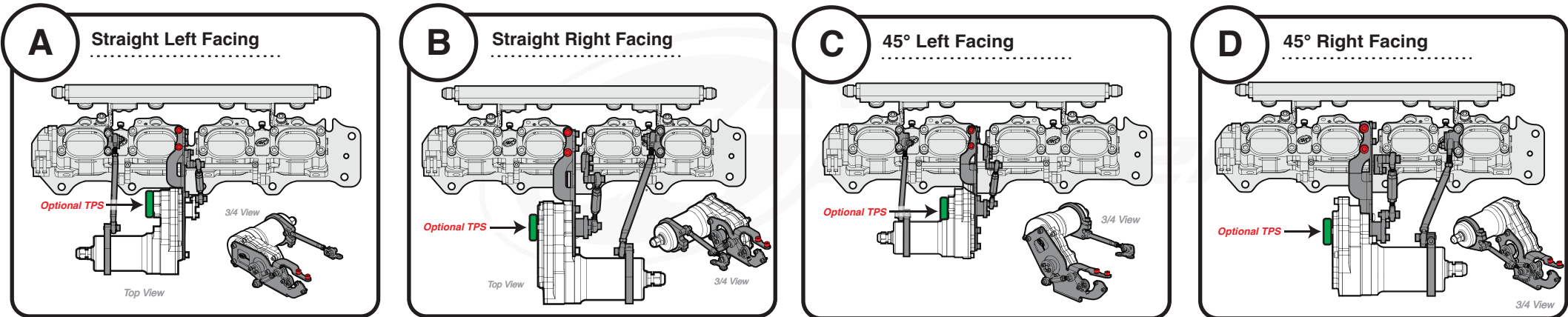

Ensure sizes fit in engine DBW Actuator bracketry technical drawings on next page

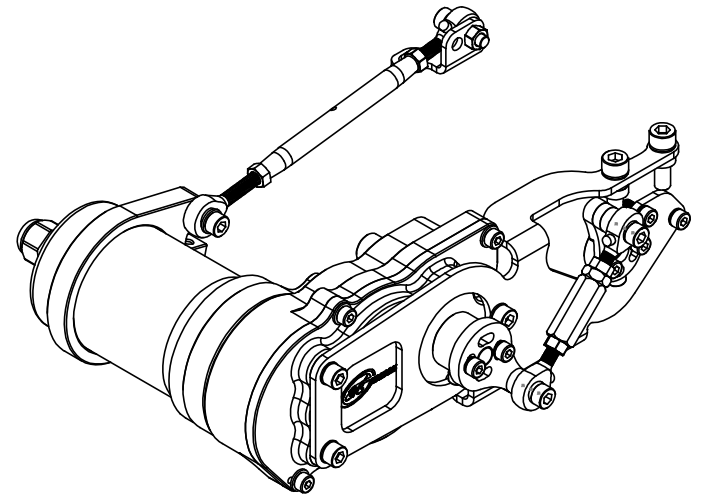
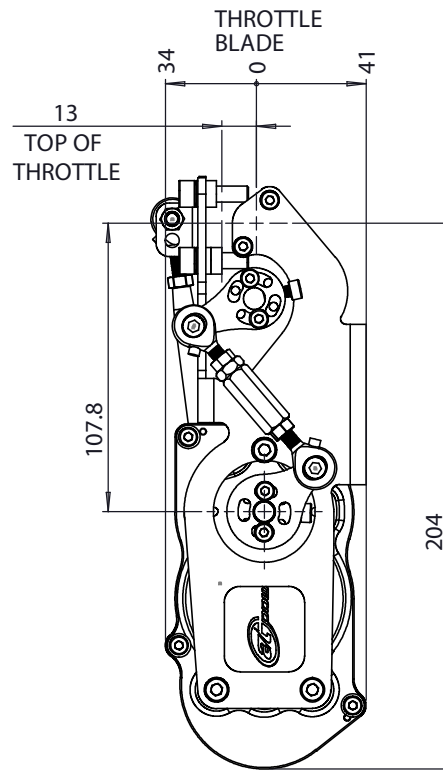
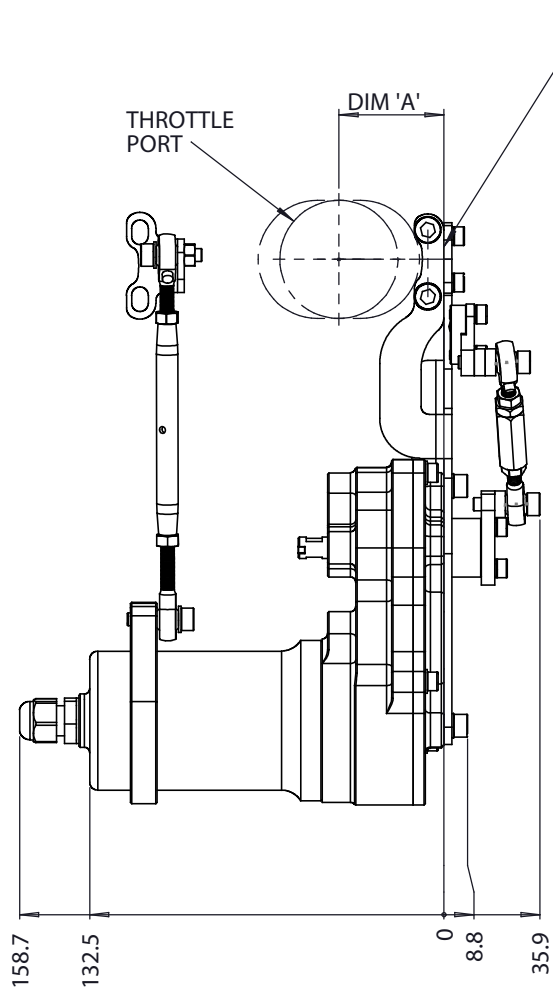

MOUNT 'A'

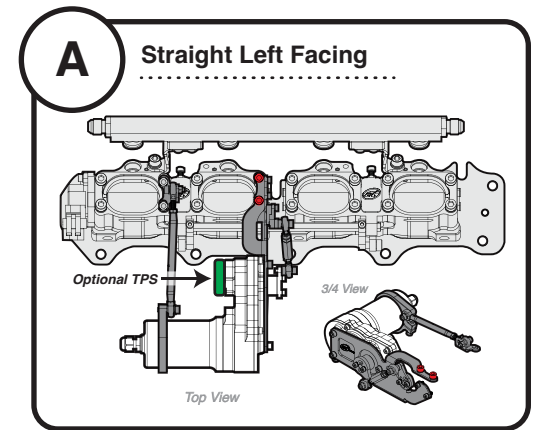

DIMENSION 'A'			
THROTTLE SIZE	TWIN OVAL THROTTLES	DCOE ROUND THROTTLES	IDA ROUND THROTTLES
36	N/A	28.5	N/A
38	31.5	29.5	N/A
40	N/A	30.5	N/A
42	34.5	31.5	N/A
45	35.5	33	N/A
48	N/A	34.5	34.5
50	41.5	N/A	35.5



S-CAN 3D Ltd
Bunns Bank Ind Est
Attleborough NR17 1QD

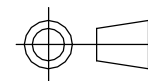

THIRD ANGLE PROJECTION

SCALE 1:2 WEIGHT 1.4 kg

DRAWN- S.HOW

DATE- 22/11/24

CHECKED - S.HOW

APPROVED - S.HOW

UNLESS OTHERWISE STATED:
DIMENSIONS IN MILLIMETRES
TOLERANCES: LINEAR ± 0.1 ANGULAR $\pm 0.5^\circ$
SURFACE FINISH $\sqrt{\text{V}}$
DRAWING STANDARDS TO ATQS 6003
DATE FORMAT: DD/MM/YY

THIS DESIGN IS THE PROPERTY OF
S-CAN 3D LTD AND MUST NOT BE
REPRODUCED OR COMMUNICATED
WITHOUT AUTHORITY

CAD PLOT
DO NOT
SCALE

MATERIAL

SEE COMPONENT PARTS

FINISH

SEE COMPONENT PARTS

DRAWING TITLE

ASSY - DBW ACTUATOR KIT -
CENTRAL MOUNT TWIN
THROTTLES - LH

DRAWING NUMBER

102-106-00055

THROTTLE PORT

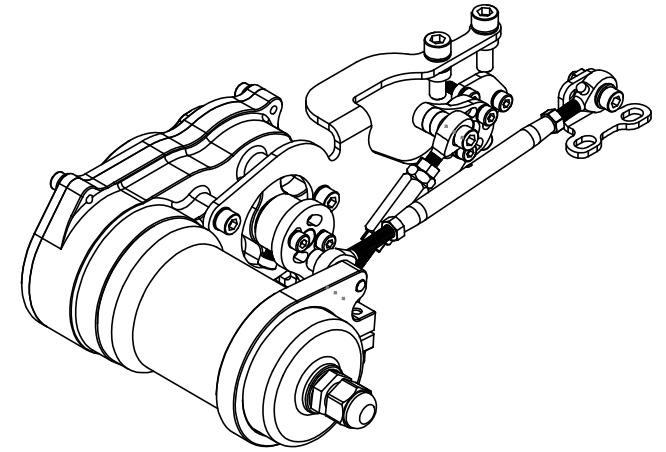
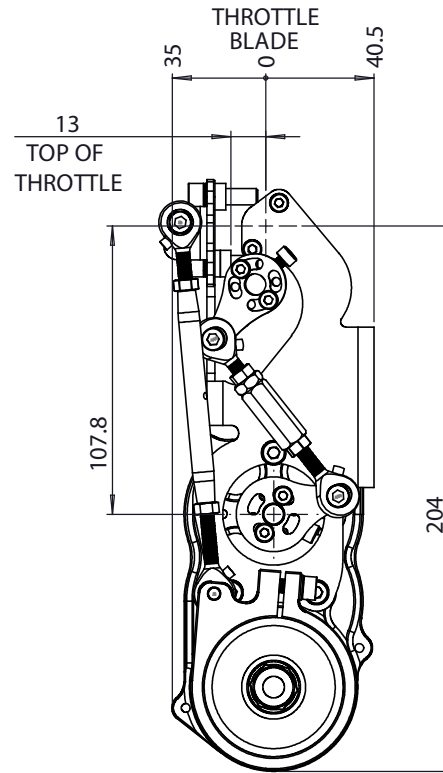
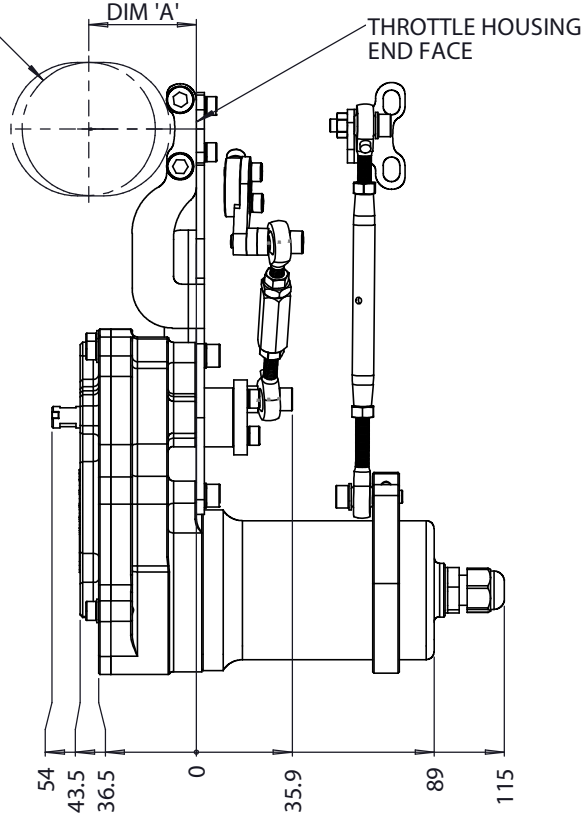

MOUNT 'B'

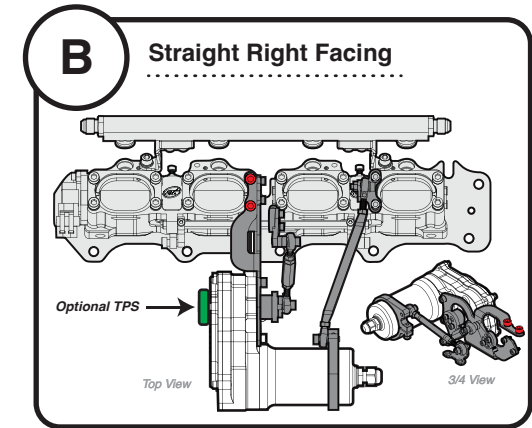

DIMENSION 'A'			
THROTTLE SIZE	TWIN OVAL THROTTLES	DCOE ROUND THROTTLES	IDA ROUND THROTTLES
36	N/A	28.5	N/A
38	31.5	29.5	N/A
40	N/A	30.5	N/A
42	34.5	31.5	N/A
45	35.5	33	N/A
48	N/A	34.5	34.5
50	41.5	N/A	35.5



S-CAN 3D Ltd
Bunns Bank Ind Est
Attleborough NR17 1QD

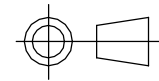

THIRD ANGLE PROJECTION
SCALE 1:2 WEIGHT 1.3 kg

DRAWN - S.HOW
DATE - 22/11/24
CHECKED - S.HOW
APPROVED - S.HOW

UNLESS OTHERWISE STATED:
DIMENSIONS IN MILLIMETRES
TOLERANCES: LINEAR ±0.1 ANGULAR ±0.5°
SURFACE FINISH √ = √
DRAWING STANDARDS TO ATQS 6003
DATE FORMAT: DD/MM/YY
THIS DESIGN IS THE PROPERTY OF S-CAN 3D LTD AND MUST NOT BE REPRODUCED OR COMMUNICATED WITHOUT AUTHORITY

CAD PLOT DO NOT SCALE

MATERIAL	SEE COMPONENT PARTS
FINISH	SEE COMPONENT PARTS
DRAWING TITLE	ASSY - DBW ACTUATOR KIT - CENTRAL MOUNT TWIN THROTTLES - RH
DRAWING NUMBER	102-106-00056

THROTTLE PORT

DIM 'A'

THROTTLE HOUSING
END FACE

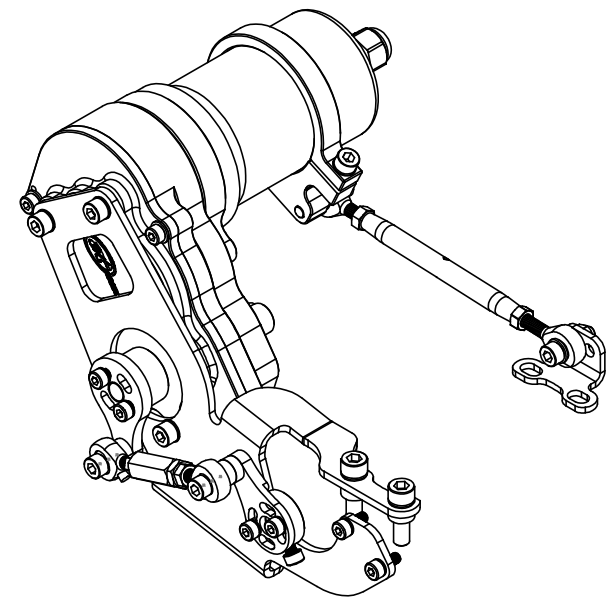
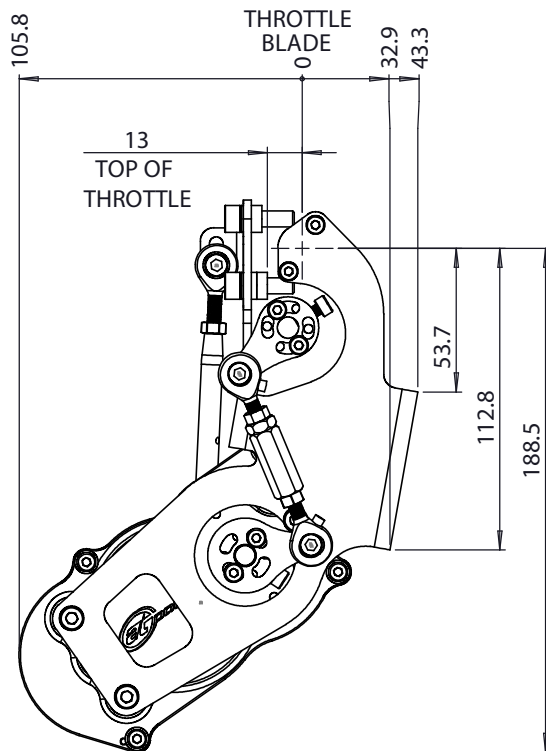
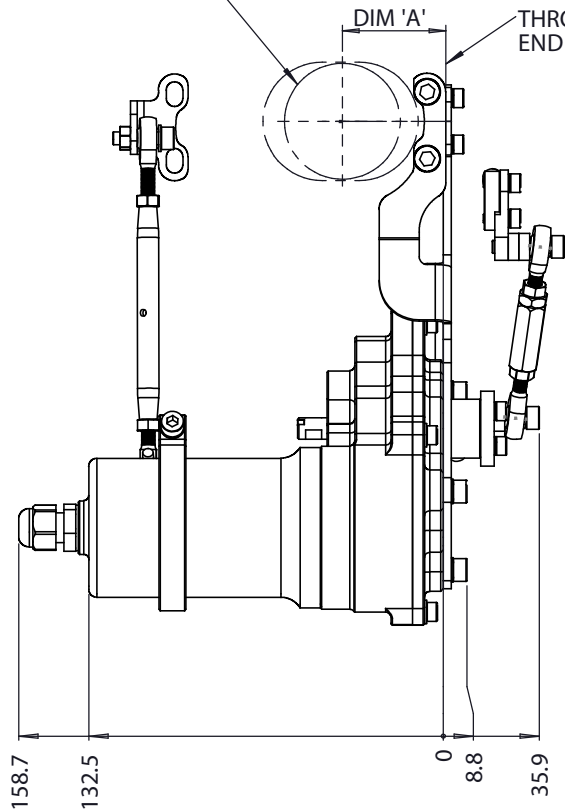

MOUNT 'C'

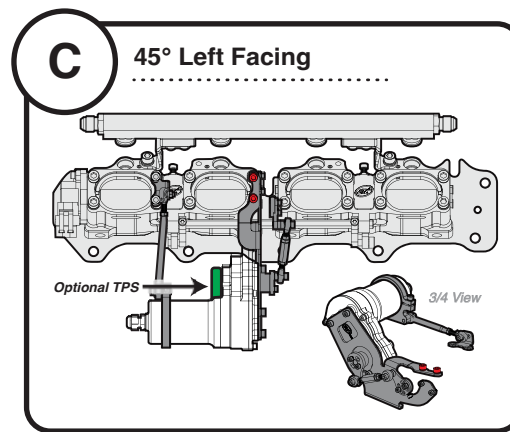

DIMENSION 'A'			
THROTTLE SIZE	TWIN OVAL THROTTLES	DCOE ROUND THROTTLES	IDA ROUND THROTTLES
36	N/A	28.5	N/A
38	31.5	29.5	N/A
40	N/A	30.5	N/A
42	34.5	31.5	N/A
45	35.5	33	N/A
48	N/A	34.5	34.5
50	41.5	N/A	35.5



S-CAN 3D Ltd
Bunns Bank Ind Est
Attleborough NR17 1QD

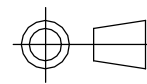

THIRD ANGLE PROJECTION

SCALE 1:2 WEIGHT 1.4 kg

DRAWN- S.HOW

DATE- 22/11/24

CHECKED- S.HOW

APPROVED- S.HOW

UNLESS OTHERWISE STATED:
DIMENSIONS IN MILLIMETRES
TOLERANCES: LINEAR ±0.1 ANGULAR ±0.5°
SURFACE FINISH √ = √
DRAWING STANDARDS TO ATQS 6003
DATE FORMAT: DD/MM/YY

THIS DESIGN IS THE PROPERTY OF
S-CAN 3D LTD AND MUST NOT BE
REPRODUCED OR COMMUNICATED
WITHOUT AUTHORITY

CAD PLOT
DO NOT
SCALE

MATERIAL

SEE COMPONENT PARTS

FINISH

SEE COMPONENT PARTS

DRAWING TITLE

ASSY - DBW ACTUATOR KIT -
CENTRAL MOUNT TWIN
THROTTLES - LH - 45 DEGREES

DRAWING NUMBER

102-106-00080

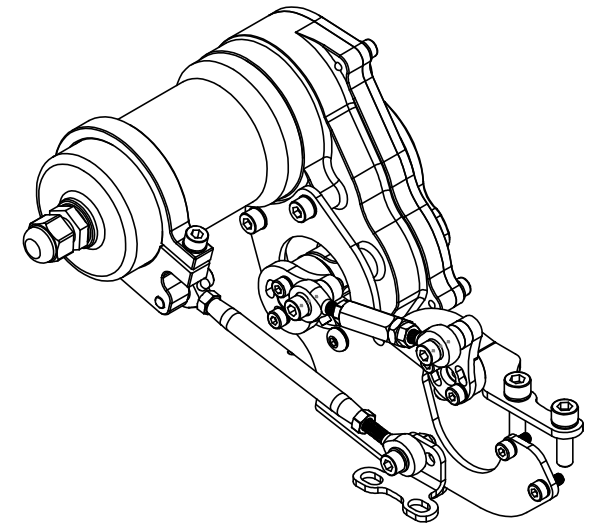
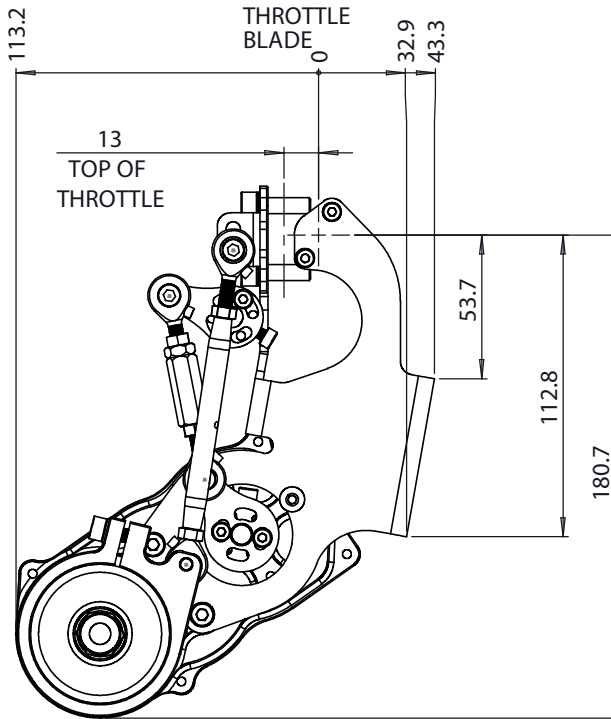
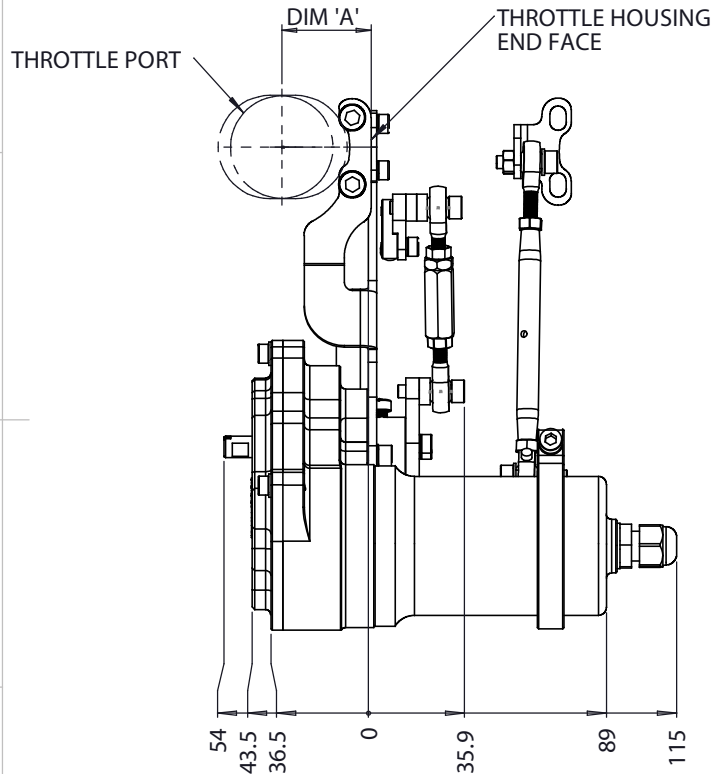

MOUNT 'D'

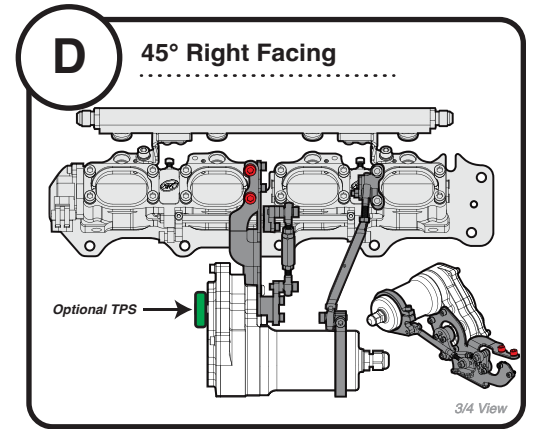

DIMENSION 'A'			
THROTTLE SIZE	TWIN OVAL THROTTLES	DCOE ROUND THROTTLES	IDA ROUND THROTTLES
36	N/A	28.5	N/A
38	31.5	29.5	N/A
40	N/A	30.5	N/A
42	34.5	31.5	N/A
45	35.5	33	N/A
48	N/A	34.5	34.5
50	41.5	N/A	35.5



S-CAN 3D Ltd
Bunns Bank Ind Est
Attleborough NR17 1QD

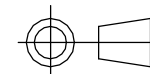

THIRD ANGLE PROJECTION

SCALE 1:2 WEIGHT 1.4 kg

DRAWN- S.HOW

DATE- 22/11/24

CHECKED- S.HOW

APPROVED- S.HOW

UNLESS OTHERWISE STATED:
DIMENSIONS IN MILLIMETRES
TOLERANCES: LINEAR ± 0.1 ANGULAR $\pm 0.5^\circ$
SURFACE FINISH $\sqrt{}$ = $\sqrt{}$
DRAWING STANDARDS TO ATQS 6003
DATE FORMAT: DD/MM/YY

THIS DESIGN IS THE PROPERTY OF
S-CAN 3D LTD AND MUST NOT BE
REPRODUCED OR COMMUNICATED
WITHOUT AUTHORITY

CAD PLOT
DO NOT
SCALE

MATERIAL

SEE COMPONENT PARTS

FINISH

SEE COMPONENT PARTS

DRAWING TITLE

ASSY - DBW ACTUATOR KIT -
CENTRAL MOUNT -TWIN
THROTTLES - RH- 45 DEGREE UP

DRAWING NUMBER

102-106-00066

SHEET 2 OF 2 A3