

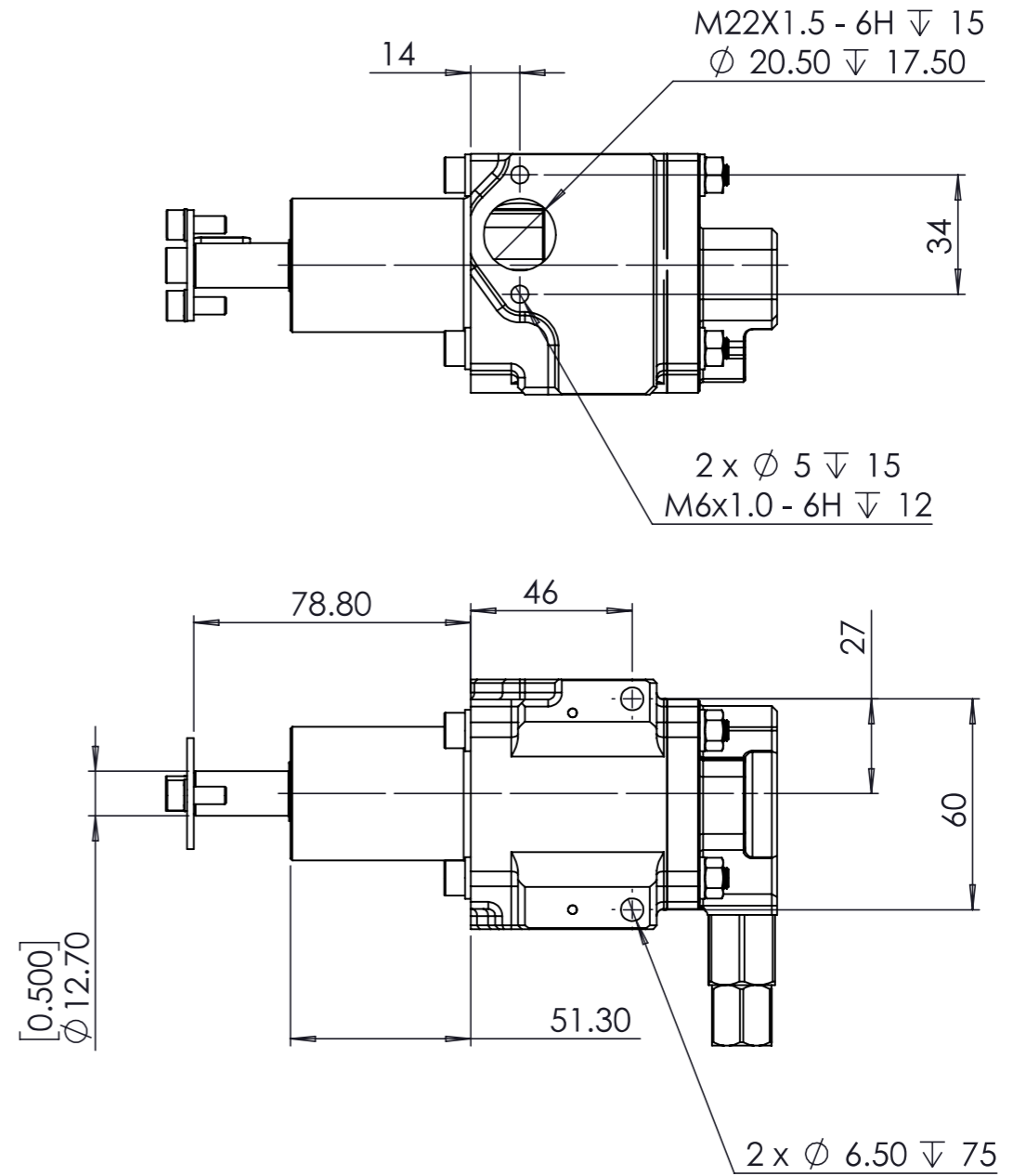

NOTES:

1. DISPLACEMENT PER REVERLUTION PER STAGE = 20.1 CC/REV
2. DISPLACEMENT AT 1000 RPM = 20.1 LT/MIN
3. PRV CRACKING PRESSURE:-  
 MINIMUM = 2.9 BAR (42 PSI)  
 MAXIMUM = 8.27 BAR (120PSI)
4. FOR EACH FULL TURN OF THE ADJUSTER THE CRACKING PRESSURE WILL INCREASE/DECREASE BY 0.25 BAR (3.6 PSI)

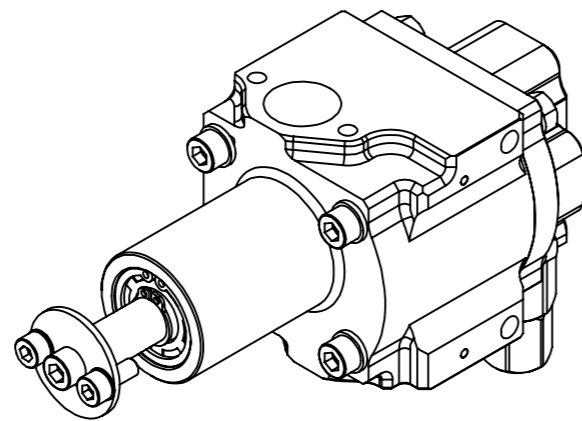
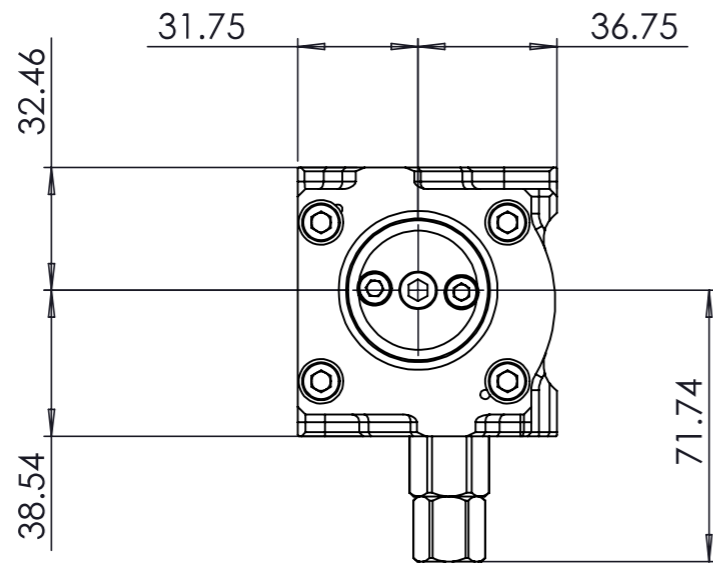
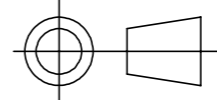

 COPYRIGHT © 2024 S-CAN 3D LTD Unit 10b, Bunn's Bank Rd, Attleborough Norfolk, UK, NR17 1QD	 THIRD ANGLE PROJECTION	MATERIAL	SEE COMPONENT PARTS
		FINISH	SEE COMPONENT PARTS
UNLESS OTHERWISE STATED: DIMENSIONS IN MILLIMETRES TOLERANCES: LINEAR $\pm 0.1$ ANGULAR $\pm 0.5^\circ$ SURFACE FINISH $\nabla = \nabla$ DRAWING STANDARDS TO ATQS 6003 DATE FORMAT: DD/MM/YY	SCALE	WEIGHT	DRAWING TITLE <b>1 STAGE CORDIS-PRESSURE                  PUMP-LONG NOSE-20.1 Lt</b>
	1:2	1.2 kg	
	DRAWN-	S.HOW	
THIS DESIGN IS THE PROPERTY OF S-CAN 3D LTD AND MUST NOT BE PRODUCED OR REPLICATED WITHOUT AUTHORITY	DATE-	17/06/19	DRAWING NUMBER <b>104-103-00078</b>
	CHECKED -	S.HOW	
CAD PLOT DO NOT SCALE	APPROVED -	A.CLIFTON	SHEET 2 OF 2 A3