

WITH THE ACTUATOR ROTATED FULLY ANTI CLOCKWISE ON THIS SIDE YELLOW DOT INDICATES MAGNETIC NORTH ON THE TPS MAGNET

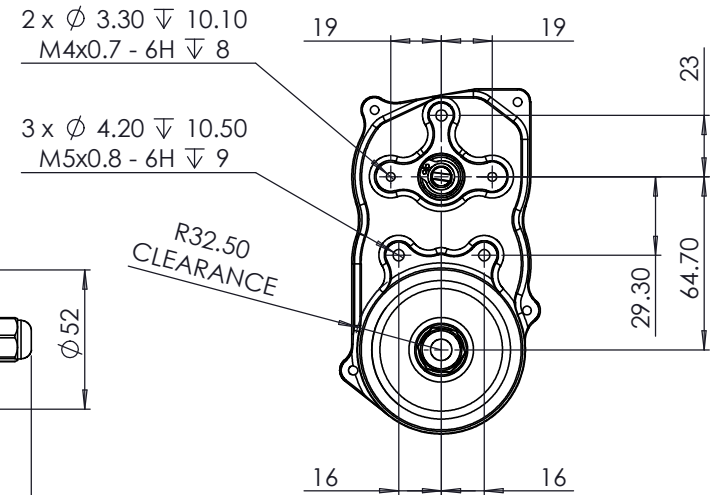

MOTOR WIRES
RED +
BLACK NEGATIVE

1. DIRECTION OF ROTATION WILL DEPEND ON THE MOUNTING ORIENTATION OF THE ACTUATOR.
2. ACTUATOR IS LIMITED TO 110° ROTATION.

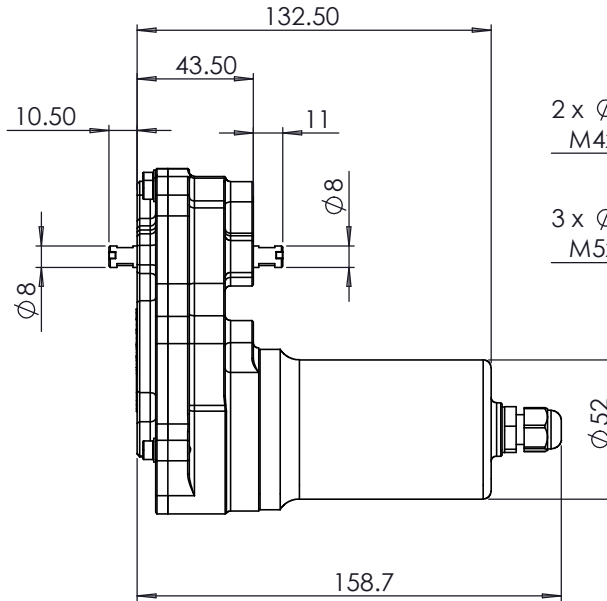
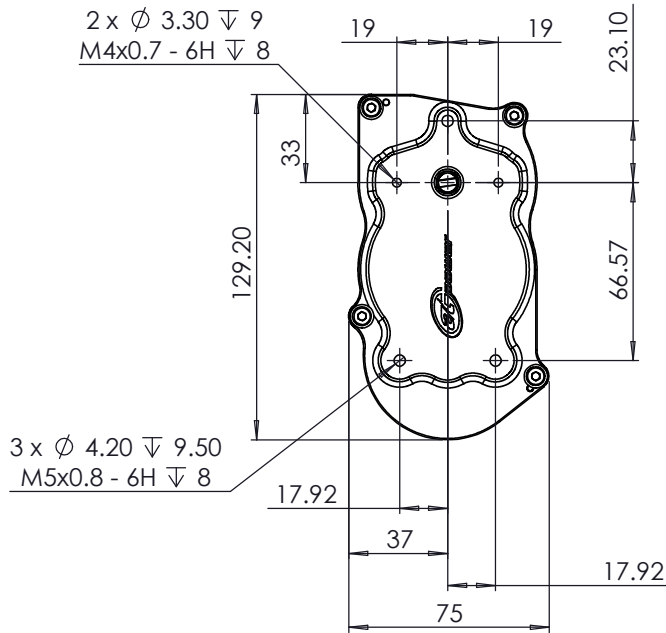
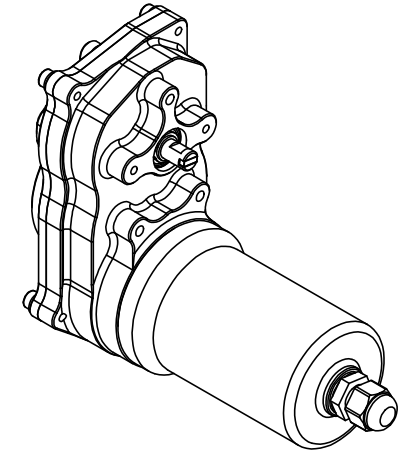
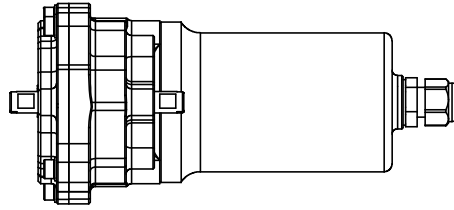
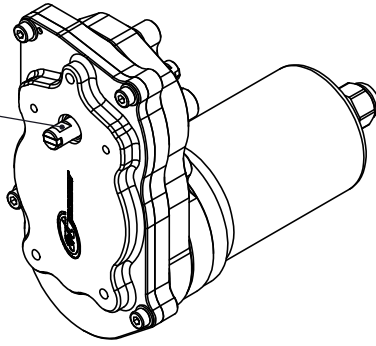

S-CAN 3D Ltd
Bunns Bank Ind Est
Attleborough NR17 1QD

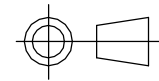

THIRD ANGLE PROJECTION
SCALE 1:2 WEIGHT 1.0 kg

DRAWN- S.HOW
DATE - 08/09/21

CHECKED - S.HOW
APPROVED - A.CLIFTON

UNLESS OTHERWISE STATED:
DIMENSIONS IN MILLIMETRES
TOLERANCES: LINEAR ± 0.1 ANGULAR ± 0.5°
SURFACE FINISH √ = √
DRAWING STANDARDS TO ATQS 6003
DATE FORMAT: DD/MM/YY
THIS DESIGN IS THE PROPERTY OF S-CAN 3D LTD AND MUST NOT BE REPRODUCED OR COMMUNICATED WITHOUT AUTHORITY

CAD PLOT DO NOT SCALE

MATERIAL	SEE COMPONENT PARTS
FINISH	SEE COMPONENT PARTS
DRAWING TITLE	ASSY - DBW ACTUATOR
DRAWING NUMBER	102-106-00053