

1. DISPLACEMENT PER REVERLUTION PER STAGE = 22.0 CC/REV
2. DISPLACEMENT AT 1000 RPM = 22.0 LT/MIN
3. PRV CRACKING PRESSURE:-
 MINIMUM = 1.6 BAR (24 PSI)
 MAXIMUM = 8.7 BAR (126PSI)
4. FOR EACH FULL TURN OF THE ADJUSTER THE CRACKING PRESSURE WILL INCREASE/DECREASE BY 0.41 BAR (6.0 PSI)

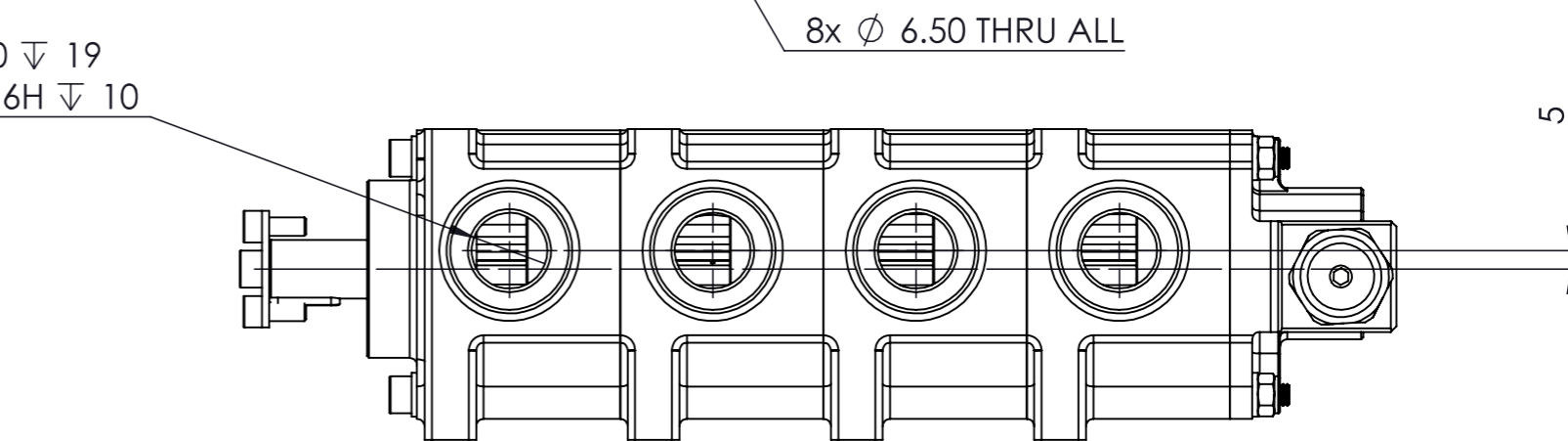
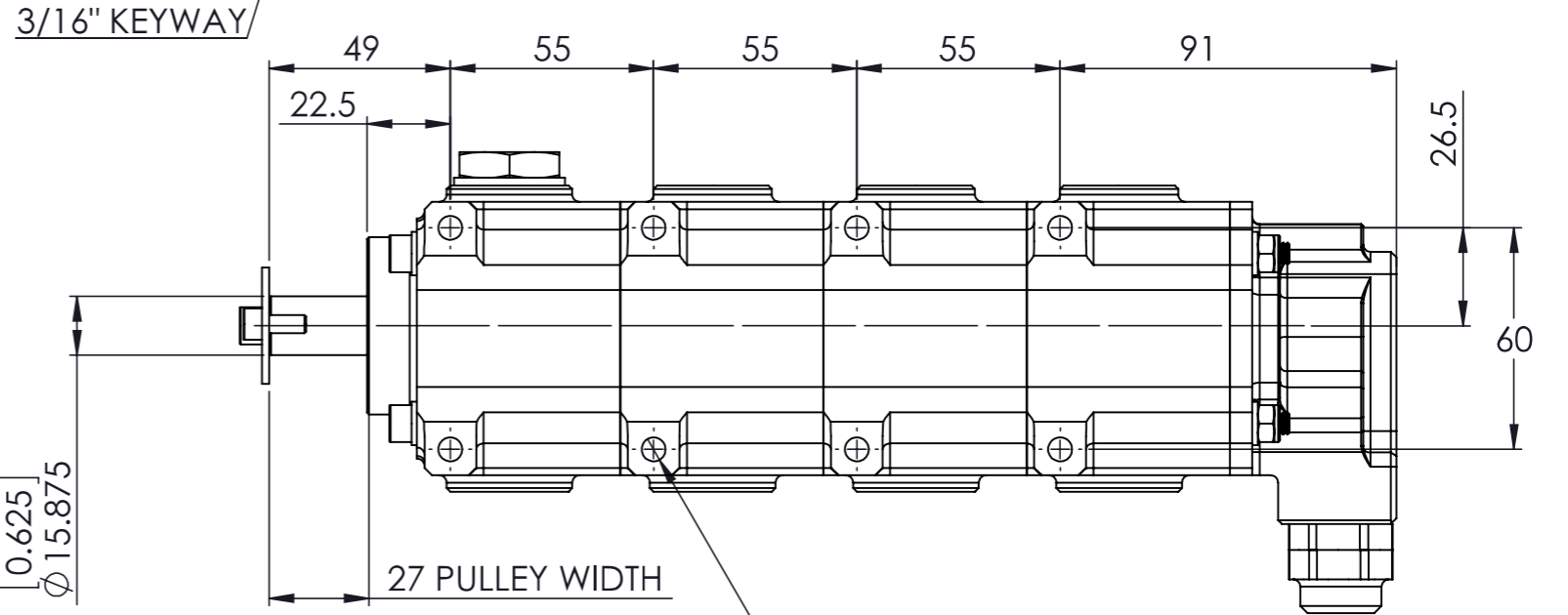
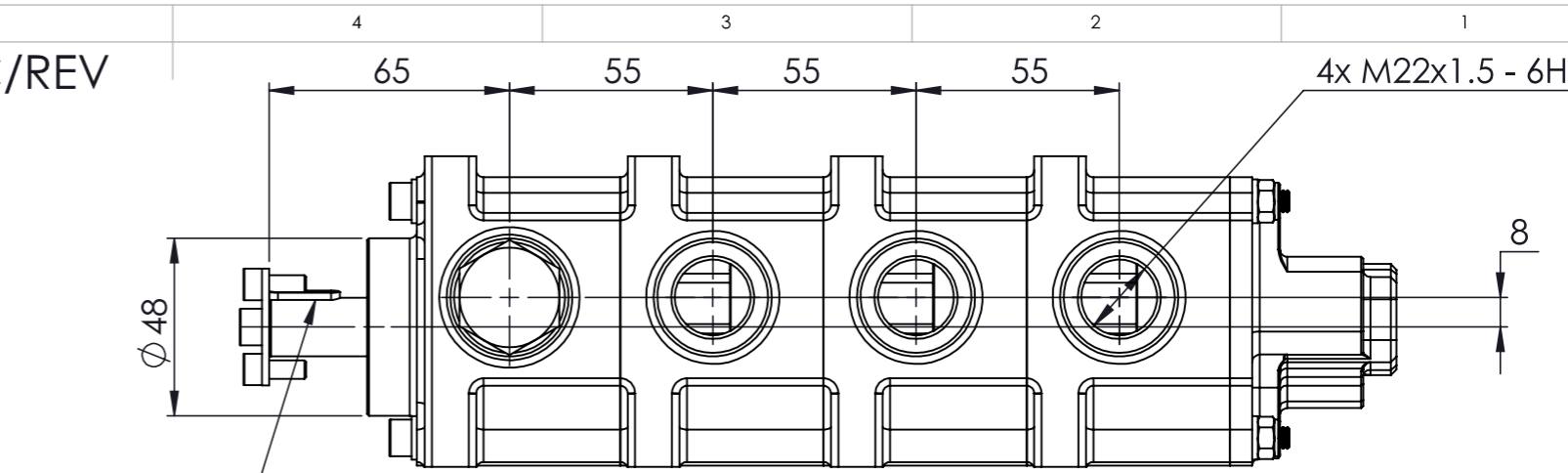
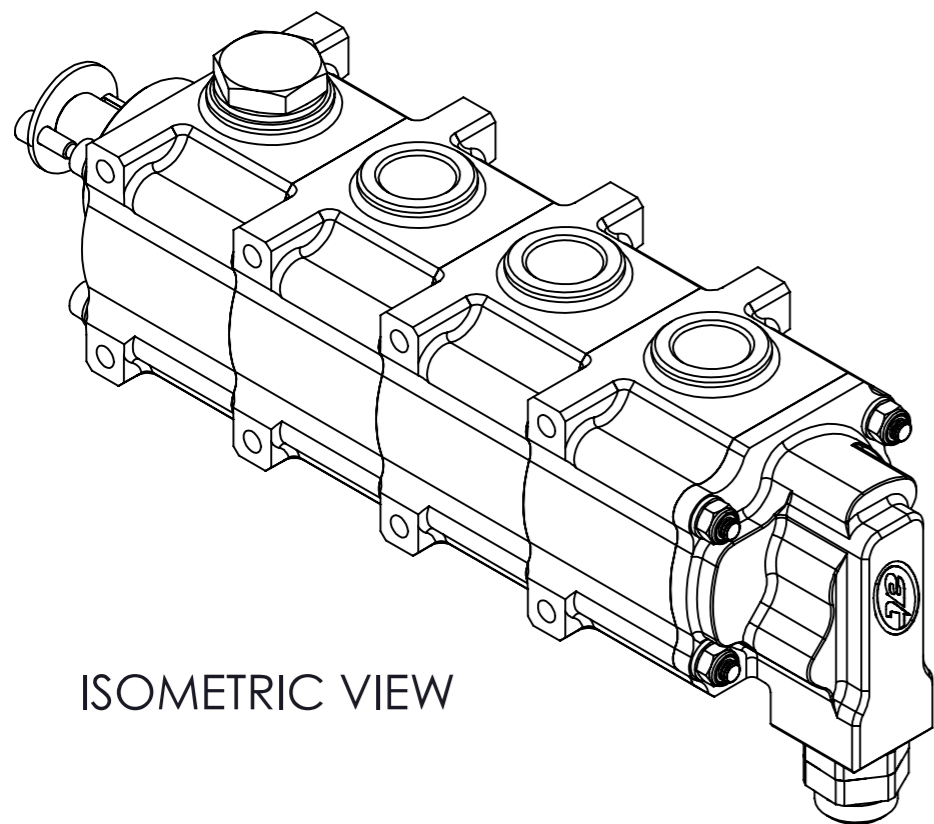
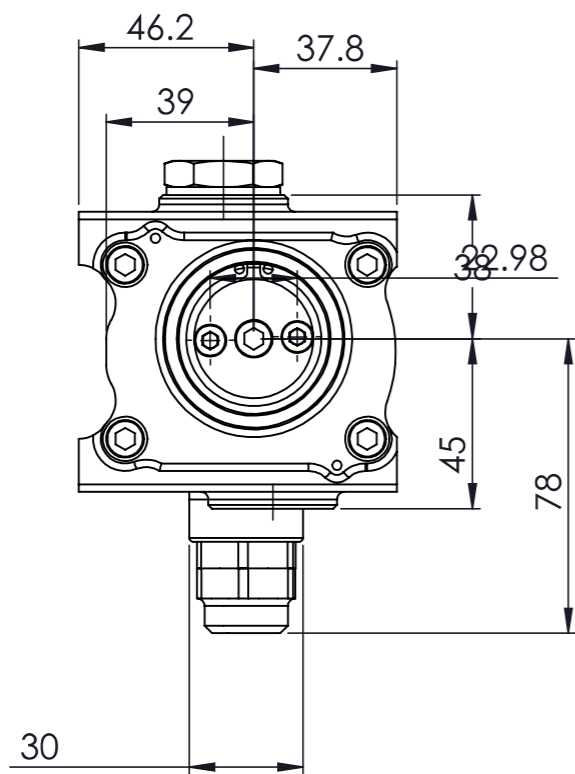

<p>COPYRIGHT © 2024 S-CAN 3D LTD Unit 10b, Bunn's Bank Ind Est, Attleborough Norfolk, UK, NR17 1QD</p>	<p>THIRD ANGLE PROJECTION</p>	MATERIAL	SEE COMPONENT PART
		FINISH	SEE COMPONENT PART
<p>UNLESS OTHERWISE STATED: DIMENSIONS IN MILLIMETRES TOLERANCES: LINEAR ± 0.1 ANGULAR ± 0.5° SURFACE FINISH √ = √ DRAWING STANDARDS TO ATQS 6003 DATE FORMAT: DD/MM/YY</p>	SCALE	WEIGHT	DRAWING TITLE
	1:2	4.3 kg	
<p>THIS DESIGN IS THE PROPERTY OF S-CAN 3D LTD AND MUST NOT BE PRODUCED OR REPLICATED WITHOUT AUTHORITY</p>	DRAWN-	S.HOW	DRAWING NUMBER
	DATE-	21/04/20	
<p>CAD PLOT DO NOT SCALE</p>	CHECKED-	S.HOW	SHEET 2 OF 2 A3
	APPROVED-	A.CLIFTON	