

NOTES:

1. DISPLACEMENT PER REVERLUTION PER STAGE = 14.3 CC/REV
2. DISPLACEMENT AT 1000 RPM = 14.3 LT/MIN
3. PRV CRACKING PRESSURE:-
 MINIMUM = 2.9 BAR (42 PSI)
 MAXIMUM = 8.27 BAR (120PSI)
4. FOR EACH FULL TURN OF THE ADJUSTER THE CRACKING PRESSURE WILL INCREASE/DECREASE BY 0.25 BAR (3.6 PSI)

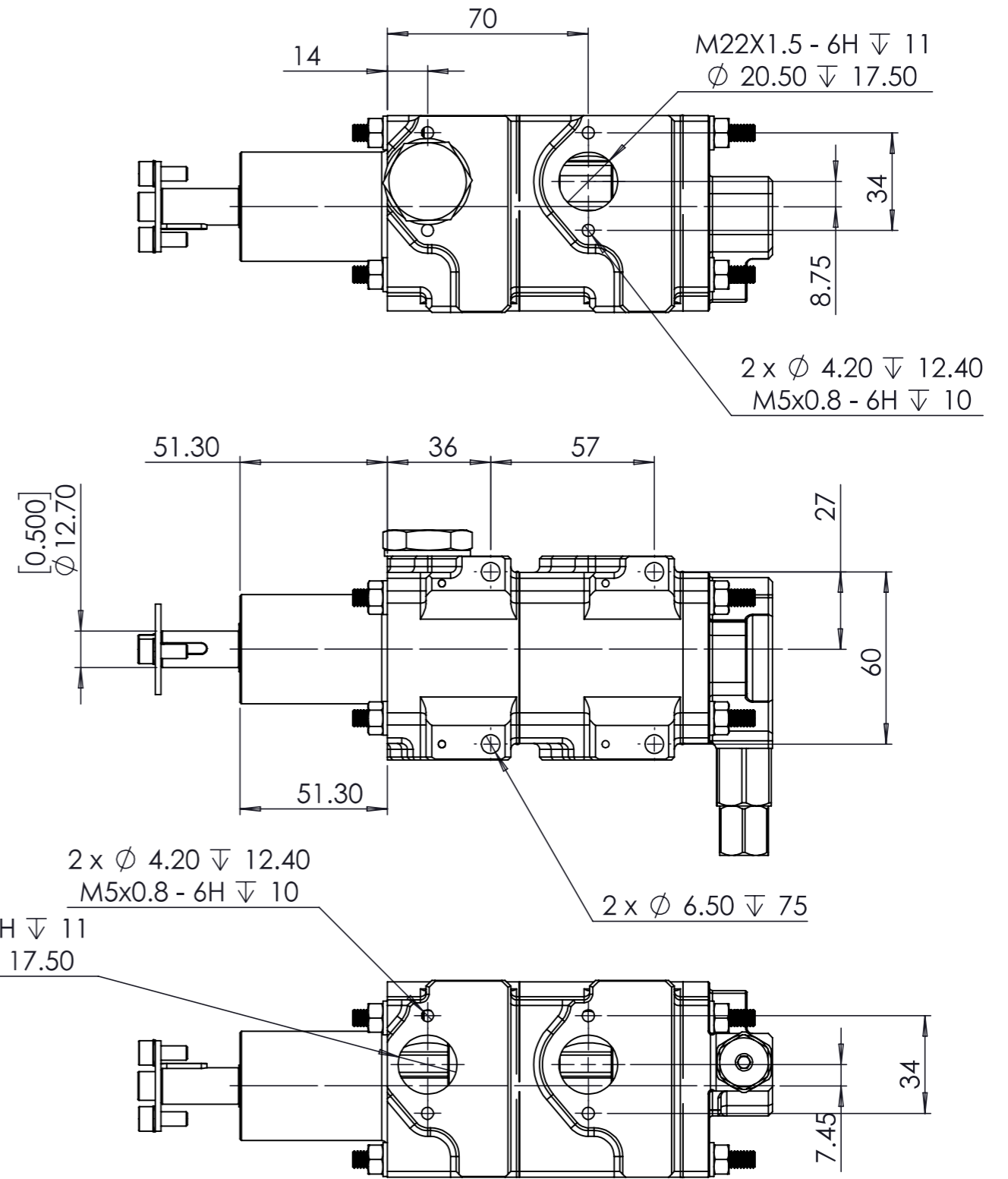
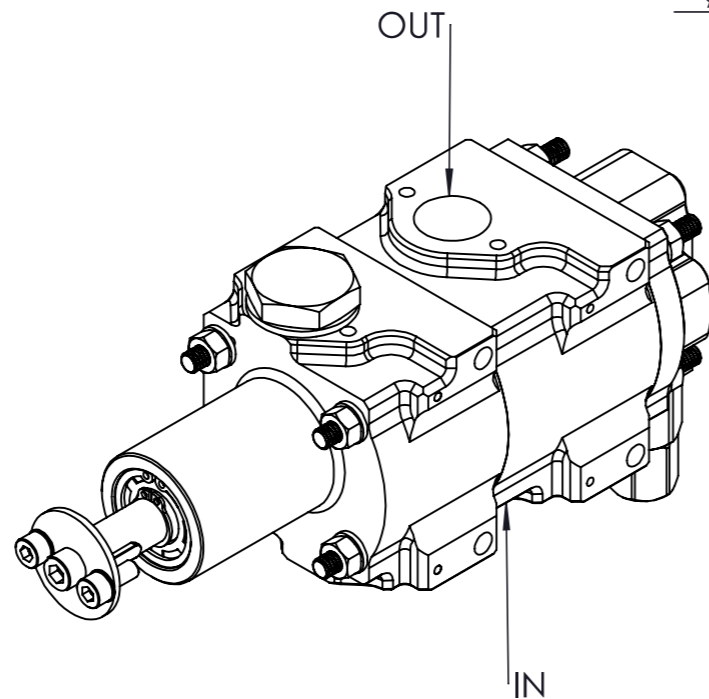
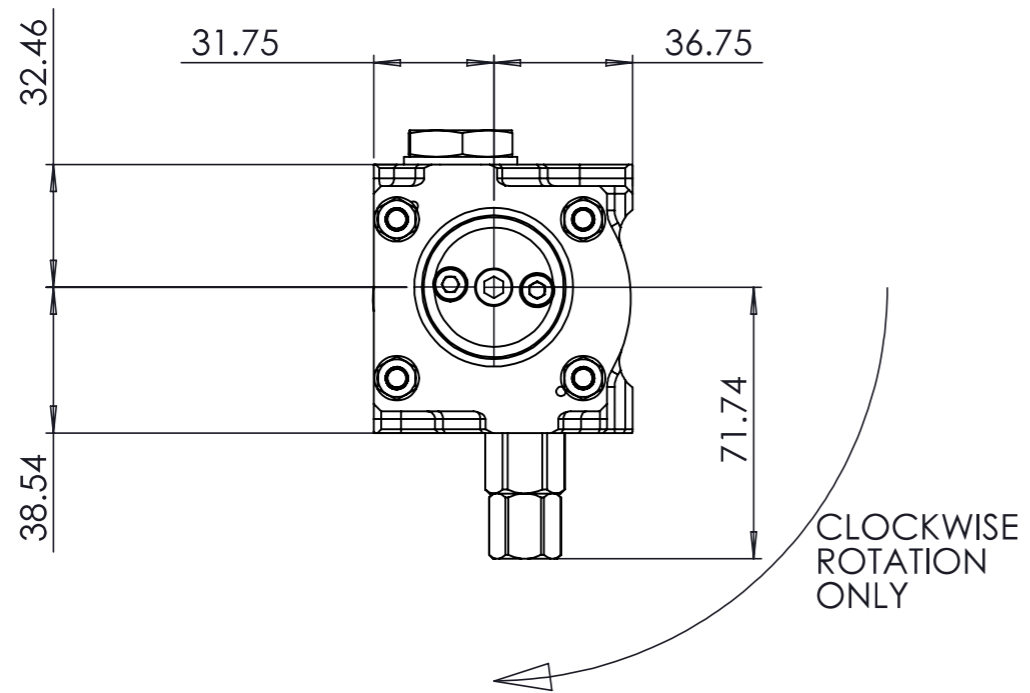

<p>COPYRIGHT © 2024 S-CAN 3D LTD Unit 10b, Bunn's Bank Ind Est, Attleborough Norfolk, UK, NR17 1QD</p>	<p>THIRD ANGLE PROJECTION</p>	MATERIAL	SEE COMPONENT PARTS
		FINISH	SEE COMPONENT PARTS
<p>UNLESS OTHERWISE STATED: DIMENSIONS IN MILLIMETRES TOLERANCES: LINEAR ± 0.1 ANGULAR ± 0.5° SURFACE FINISH ∇ = ∇ DRAWING STANDARDS TO ATQS 6003 DATE FORMAT: DD/MM/YY</p>	SCALE	WEIGHT	DRAWING TITLE
	1:2	1.8 kg	
<p>THIS DESIGN IS THE PROPERTY OF S-CAN 3D LTD AND MUST NOT BE PRODUCED OR REPLICATED WITHOUT AUTHORITY</p>	DRAWN-	DATE-	DRAWING NUMBER
	S.HOW	21/04/20	
CAD PLOT DO NOT SCALE	CHECKED -	APPROVED -	SHEET 2 OF 2 A3
	S.HOW	A.CLIFTON	