

ALL PUMP FITTINGS
M22X1.5 - 6H ∇ 11
 ϕ 20.5 ∇ 17.5

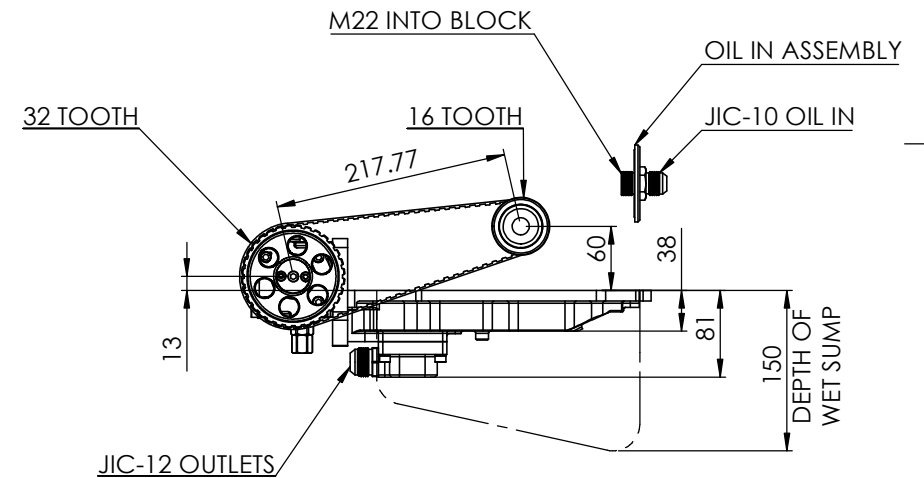
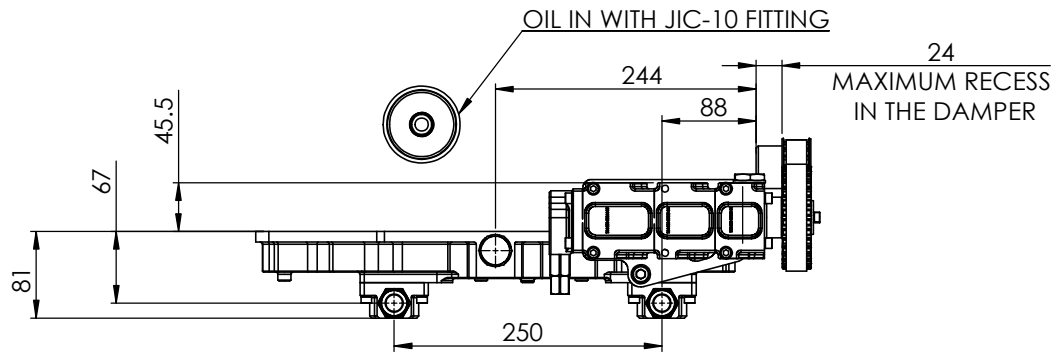

NOTES:

1. SCAVENGE DISPLACEMENT PER REVOLUTION PER STAGE = 14.3 CC/REV
2. SCAVENGE DISPLACEMENT AT 1000 RPM = 14.3 LT/MIN
3. PUMP DISPLACEMENT PER REVOLUTION PER STAGE = 20.1 CC/REV
4. PUMP DISPLACEMENT AT 1000 RPM = 20.1 LT/MIN
5. PRV MINIMUM CRACKING PRESSURE = 52 PSI (3.58 BAR)
6. PRV MAXIMUM CRACKING PRESSURE = 146 PSI (10.0 BAR)
7. EACH FULL TURN OF THE PRV ADJUSTER THE CRACKING PRESSURE WILL INCREASE/DECREASE BY 4.3 PS (0.3 BAR)

NOTE:
PUMP DISPLACEMENT IS FOR GUIDEANCE ONLY AS EFFECIENCY IS INFUENCED BY MULTIPLE FACTORS

THIS SYSTEM IS SUITABLE FOR ENGINES RUNNING AT A MAXIMUM OF 9500 RPM

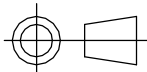
| | | | |
|---|---|--|---------------------------------|
|  S-CAN 3D Ltd Bunn's Bank Ind Est Attleborough NR17 1QD |  THIRD ANGLE PROJECTION | | MATERIAL SEE COMPONENT PARTS |
| | SCALE 1:3 | WEIGHT 6.1 kg | FINISH SEE COMPONENT PARTS |
| UNLESS OTHERWISE STATED: DIMENSIONS IN MILLIMETRES TOLERANCES: LINEAR \pm 0.1 ANGULAR \pm 0.5° SURFACE FINISH ∇ = ∇ DRAWING STANDARDS TO ATQS 6003 DATE FORMAT: DD/MM/YY | DRAWN- S.HOW | DRAWING TITLE ASSY - SUMP KIT - HONDA - K20/24 - 3/4" BELT - EXHAUST | |
| THIS DESIGN IS THE PROPERTY OF S-CAN 3D LTD AND MUST NOT BE REPRODUCED OR COMMUNICATED WITHOUT AUTHORITY | DATE - 30/03/21 | DRAWING NUMBER 105-102-00048 | |
| CAD PLOT DO NOT SCALE | CHECKED - S.HOW | SHEET 2 OF 2 A3 | |
| | APPROVED - S.HOW | | |