



Drive-By-Wire Electronic Actuator Throttle Control Installation Guide

Read thoroughly before installing any AT Power products.

Designed and manufactured in-house in the UK.

We reserve the right to modify this documents content or make technical changes without notice. Copyright Notice © S-CAN 3D Ltd.

Safety Information



WARNING!

Please read this guide carefully before installation.

Motorsport or driving activities can be dangerous and can result in serious personal injury or death. Please read all fitting instructions thoroughly before proceeding with installation.

AT Power (part of S-CAN 3D Ltd.) automotive products are designed for motorsport use only. We accept no responsibility for improper use of our products, and we make no warranty regarding their ability to prevent injury or death. The performance, durability, and safety of this equipment are directly dependent on correct installation, usage, and maintenance. By using this product, the user voluntarily assumes all risks associated with its use.

Installing AT Power products on vehicles subject to manufacturer's warranty may void the manufacturer's warranty and the vehicle's compliance to meet emissions and other transport regulations.

Working on a vehicle involves inherent risks. If you are unsure of what you're doing, please entrust all mechanical and safety-critical tasks to a qualified professional. S-CAN 3D Ltd, accepts no liability for any incorrect installation or misuse of its products.

Please do not dispose of AT Power products in household waste. To help protect the environment and human health from the impact of improper disposal, recycle it responsibly to support the sustainable reuse of materials.

Serial Number(s)



For future access to our product services, please record your serial number(s) here. You can find them on the product label. Distributors, kindly share this information with your customers. Please retain this manual.

Warranty Disclaimer

S-CAN 3D Ltd.
Unit 10b Bunns Bank Ind Est
Attleborough
Norfolk
NR17 1QD
United Kingdom

Dear Customer,

Thank you for choosing an AT Power product. We hope your order has arrived in the same pristine condition it left our facility. If you notice any transport damage or manufacturing faults, please notify S-CAN 3D Ltd within three business days of delivery.

All AT Power products come with a 12-month manufacturer's warranty from the date of delivery, subject to the parts being installed correctly and run within their specification. Please save this installation manual.

Additionally, we also offer refurbishment services to extend the life of your AT Power products. For more information and to get a quote, please contact us via email.

Please note that S-CAN 3D Ltd is not liable for defects caused by normal wear and tear, intentional damage, negligence, improper conditions, misuse, unauthorised alterations, or any actions or omissions by the Customer, their employees, agents, or any third party. Failure to follow AT Power's instructions (whether written or oral) will result in the warranty being voided, without exception.

For full terms and conditions, please visit AT Power's website or contact us directly for assistance.

Sincerely,

James Senior
Managing Director
S-CAN 3D Ltd.

Contents

3..... Safety Information	Optional:
4..... Warranty Disclaimer	7..... AT Power Linkage Lever
5..... Introduction	7..... AT Power Mounting Brackets
5..... Set Up and Calibration	8..... Variohm XPK Position Sensor
6..... About Drive-by-Wire Actuator	
6..... Actuator Specification	10.... Drive-By-Wire Technical Drawing

Introduction

The AT Power Electronic Throttle Actuator delivers a fast and responsive Drive-By-Wire solution (DBW) for both twin and universal throttle systems.

All key components, except the electric motor, are designed, developed, and manufactured by AT Power. The actuator features a DC motor with reduction gearing for maximum torque and operational speed, supporting a 110° sweep in both directions.

We offer an upgrade service to convert your AT Power Throttles from Cable Pull to DBW. Proper linkage setup is essential for optimal throttle blade movement. Please contact us for this service as any self-modifications will void the warranty.

Set Up and Calibration:

⚠ IMPORTANT: Do not drive the throttles or actuators forcefully into their mechanical stops. Complete and verify proper tuning before usage. If the system has not been calibrated before ignition, immediate failure is likely. Contact your ECU supplier for guidance.

Our DTH throttles do not support limp home mode.

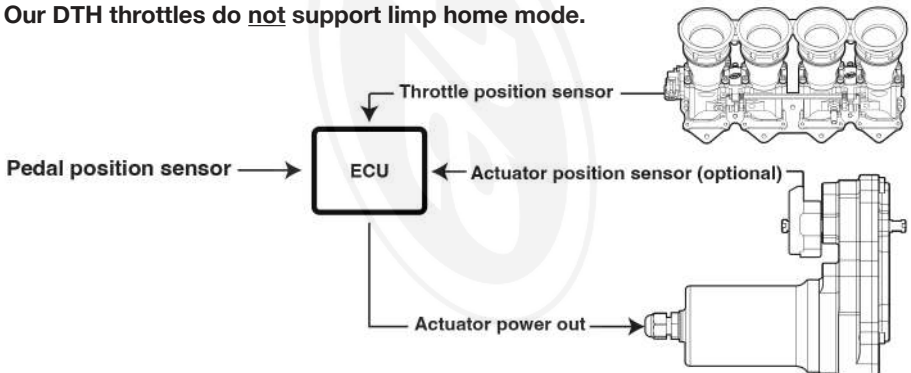

The red and black wires from the top of the actuator connect to the ECU and control throttle opening and closing.

About AT Power's Drive-by-Wire Actuator

Advantages of Electronic Actuation (if supported by the ECU)

- Auto-blip for paddle shift
- Launch control
- Anti-lag
- Switchable pedal maps
- Push-to-pass strategies
- Pit lane speed control
- Traction control
- Variable bank-to-bank control
- Warm-up mode (increased airflow)
- Optional Linkage Lever
- Optional AT Power Mounting Bracketry
- Does not support limp home mode

In all cases, it is essential to consult the ECU supplier regarding proper tuning of the actuator control system (typically PID or PI control) and the associated safety strategies.

Overall, electronic throttle systems are safer than mechanical cable systems because they continuously cross-check pedal position against throttle position and can actively power the throttle closed if required.

Actuator Specification

SKU: 102-106-00053

Mechanical Specification

Temp Range of Operation	-20°C to 130°C
Voltage Range	10V - 14V
Gear Ratio	14.66/1
Max Torque	775N-cm
Max Continuous Torque	115N-cm (at output shaft)
Linkage Levers Spacing	25mm centre's (equivalent to 287.5N / 29.3Kg force)
Max Current Draw	18.6 A
Continuous Current Draw	3.13 A
Rotation Range	110°
Weight	1065g
Operation Speed	Approx. 0.062 sec over 82° throttle movement

Electronic soft stops must be programmed into ECU which may increase blade movement

Output Shaft

The actuator output shaft is limited to a 110° rotation. The yellow dot at fully anticlockwise (N) indicates magnetic north on the TPS magnet.

Electronic Connector Options

Stand-Alone Unit	2-pin AMP Super-Seal male & female connector (available separately)
With TPS	6 pin Sealed male & female connector (available separately)

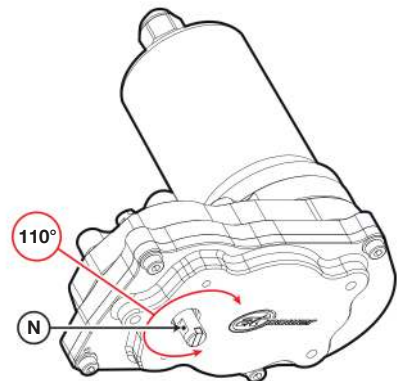

Optional AT Power Linkage Lever

SKU: 102-115-00160

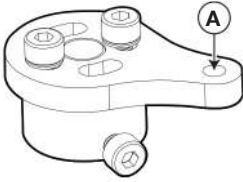

An optional AT Power linkage lever can be supplied pre-installed or as a separate component for user installation.

The lever has 25mm centres and includes an M5 tapped hole (A) for attaching additional linkage mechanisms.

The lever can be screwed at any orientation within 360° to suit the desired operating location, mounted on either the outside or inside of the actuator housing, depending on the TPS location (note: TPS might not be required).

Inside Positioning

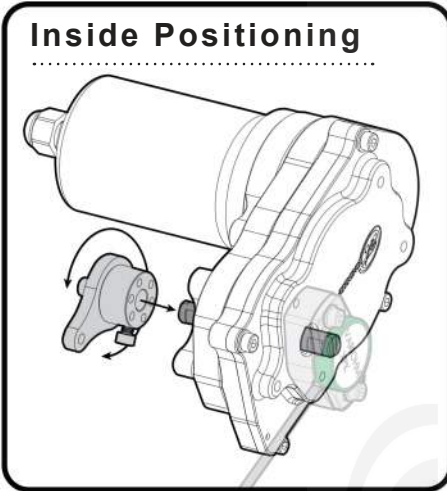

Outside Positioning

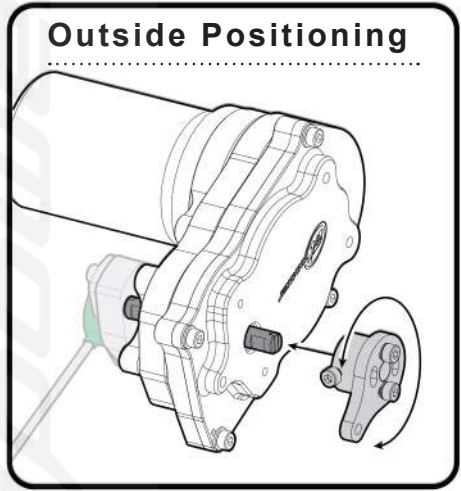

Optional AT Power Standard Mounting Brackets

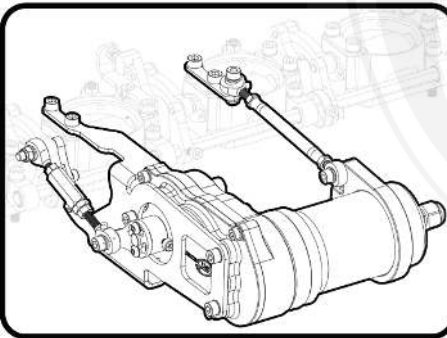

If ordered, the linkage is driven from the underside of our throttles, with the actuator mountable on the opposite side if required. The linkage assembly allows a 360° rotational positioning and precise adjustment.

The Actuator can be mounted at the front end of AT Power throttles with a direct connection onto the layshaft. (This option is only available upon request).

If you require a special mounting bracket, please contact us.

Optional Variohm XPK Position Sensor

AT Power can provide a dual, fully redundant, contactless position sensor that is customisable to suit individual requirements. The TPS can be mounted on either side of the actuator as shown below. Optional linkage assembly would be installed on the opposite side.

TPS Outside Housing

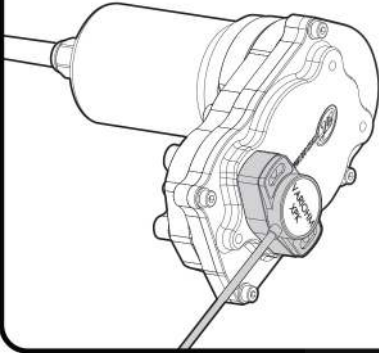

TPS Inside Housing

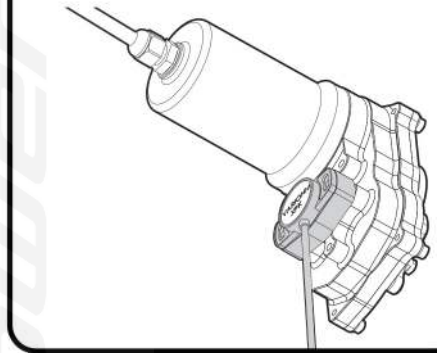

On throttles, the adjustable idle stop should be set to define the fully closed position, while the ECU should be calibrated to provide electronic soft stops for both fully open and fully closed positions.

If you require a TPS on your existing AT Power Throttles or additional TPS units, please contact us and provide your serial number for further assistance.

Variohm Euro: XPK Puck Type Programmable sensor

Orientation programmed per order, specific to application.

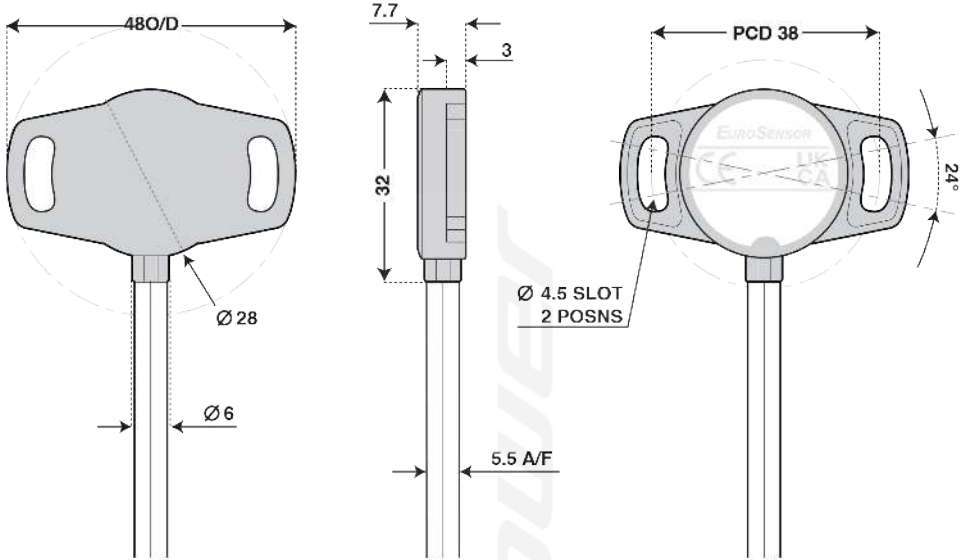

Mechanical Specification

Typical Life Cycle	In excess of 100 million cycles
Measuring Range	360° redundant, signal 1 cw, signal 2 ccw
Housing	High grade temperature resistant plastic

Environmental Specification

Operating Temperature	-40° C to +125° C (Short term 150° C)
Vibration	5...2000 Hz; Amax = 0.75 mm; amax = 20g to IEC 60068-2-6
IP rating	IP68 (minimum)

Electrical Specification

Supply Voltage	5V +/- 0.5V
Output Signal	Ratio metric 5%...95% of supply (+/-25mv of specified electrical output range for both start & end voltage)
Independent Linearity	+/- 0.5% of each signal range
Sample Rate (Fast Mode)	5 kHz
System Propagation Delay (Fast Mode)	600µs
Isolation Resistance	200 MΩ (500 VDC, 1 bar, 2s)
Cable Type	Raychem Spec 55, 24 AWG; Sleeving - Raychem DR25

Pin and Wiring Information

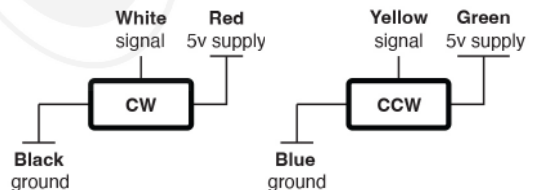

XPK SKU: 101-130-00031-01
 MOUNT SKU: 102-214-00205
 ASSEMBLY SKU: 102-119-0019

Drive-by-Wire Actuator Technical Drawings

SKU: 102-106-00053 08.09.21

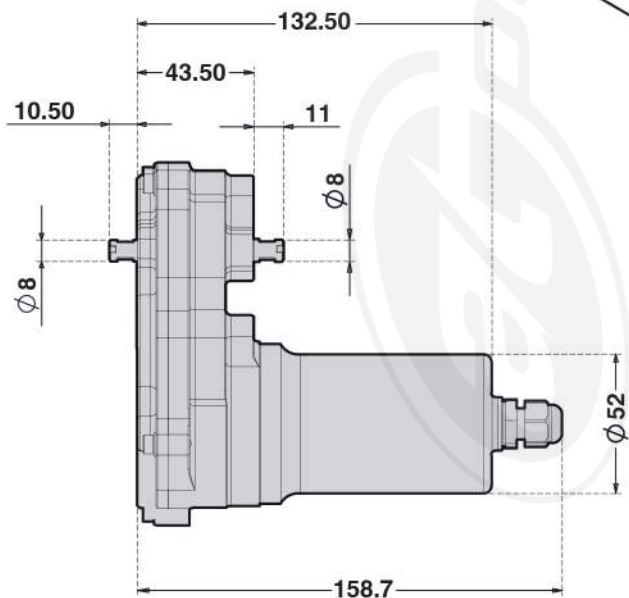
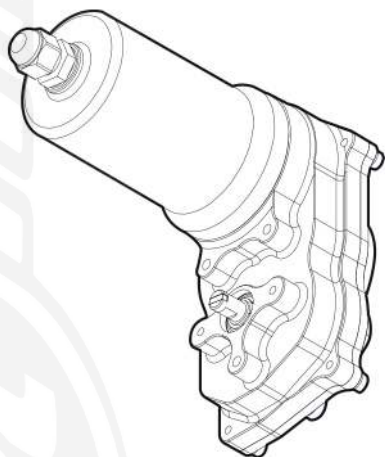
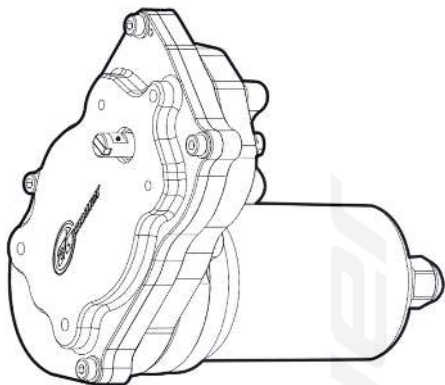

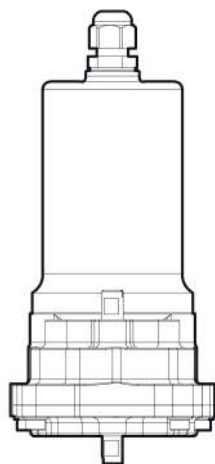

2 x ϕ 3.30 ∇ 9
M4x0.7 - 6H ∇ 8

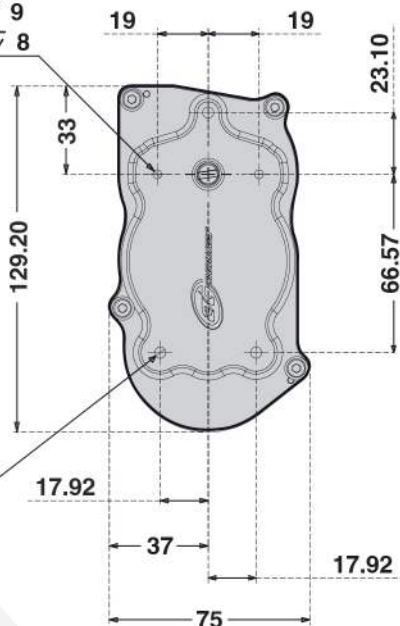

3 x ϕ 4.20 ∇ 9.50
M5x0.8 - 6H ∇ 8

2 x ϕ 3.30 ∇ 10.10
M4x0.7 - 6H ∇ 8

3 x ϕ 4.20 ∇ 10.50
M5x0.8 - 6H ∇ 9

R32.50 CLEARANCE

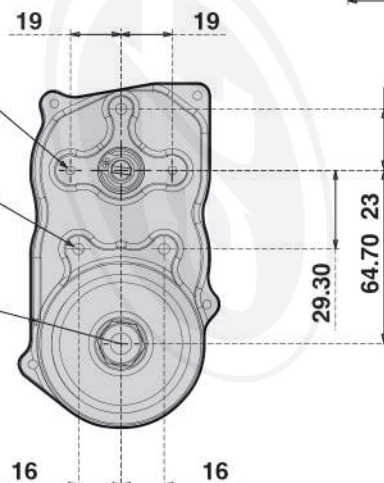



Tag us in your engine build!



Connect via WhatsApp

www.atpower.com

Tel: +44 1953 875800

info@atpowerthrottles.com

**S-CAN 3D Ltd, Unit 10b Bunns Bank Ind Est,
Attleborough, Norfolk, NR17 1QD, United Kingdom**

