



## **General Installation Guide For Belt Driven Dry Sumps And Oil Pumps**

**Read thoroughly before installing any AT Power products.**

*Designed and manufactured in-house in the UK.*

We reserve the right to modify this document's content or make technical changes without notice. Copyright Notice © S-CAN 3D Ltd.

## Safety Information

---



### **WARNING!**

**Please read this guide carefully before installation.**

Motorsport or driving activities can be dangerous and can result in serious personal injury or death. Please read all fitting instructions thoroughly before proceeding with installation.

AT Power (part of S-CAN 3D Ltd.) automotive products are designed for motorsport use only. We accept no responsibility for improper use of our products, and we make no warranty regarding their ability to prevent injury or death. The performance, durability, and safety of this equipment are directly dependent on correct installation, usage, and maintenance. By using this product, the user voluntarily assumes all risks associated with its use.

Installing AT Power products on vehicles subject to manufacturer's warranty may void the manufacturer's warranty and the vehicle's compliance to meet emissions and other transport regulations.

Working on a vehicle involves inherent risks. If you are unsure of what you're doing, please entrust all mechanical and safety-critical tasks to a qualified professional. S-CAN 3D Ltd, accepts no liability for any incorrect installation or misuse of its products.

Please do not dispose of AT Power products in household waste. To help protect the environment and human health from the impact of improper disposal, recycle it responsibly to support the sustainable reuse of materials.

## Serial Number(s)

---

 _____ _____
---

For future access to our product services, please record your serial number(s) here. You can find them on the product label. Distributors, kindly share this information with your customers. Please retain this manual.

# Warranty Disclaimer

---

S-CAN 3D Ltd.  
Unit 10b Bunns Bank Ind Est  
Attleborough  
Norfolk  
NR17 1QD  
United Kingdom

Dear Customer,

Thank you for choosing an AT Power product. We hope your order has arrived in the same pristine condition it left our facility. If you notice any transport damage or manufacturing faults, please notify S-CAN 3D Ltd within three business days of delivery.

All AT Power products come with a 12-month manufacturer's warranty from the date of delivery, subject to the parts being installed correctly and run within their specification. Please save this installation manual.

Additionally, we also offer refurbishment services to extend the life of your AT Power products. For more information and to get a quote, please contact us via email.

**Please note that S-CAN 3D Ltd is not liable for defects caused by normal wear and tear, intentional damage, negligence, improper conditions, misuse, unauthorised alterations, or any actions or omissions by the Customer, their employees, agents, or any third party. Failure to follow AT Power Throttles' instructions (whether written or oral) will result in the warranty being voided, without exception.**

**For full terms and conditions, please visit AT Power's website or contact us directly for assistance.**

Sincerely,

James Senior  
Managing Director  
S-CAN 3D Ltd.

## Contents

---

- 3..... Safety Information
- 4..... Warranty Disclaimer
- 5..... Tools and Parts Required
- 6..... General Dry Oil Sump Pan Installation

## Tools & Parts Required

---

The tools and parts required for installing AT Power's belt driven dry sump pan and oil pump are:

- A. Brake Cleaner or Degreaser
- B. RTV Silicone Sealant
- C. M6 or M8 Screws (see schematics for your sump type)
- D. Loctite 242 or equivalent
- E. 4mm Allen Key (for M5 screws, pulley attachment and PRV Adjustment)
- F. 5mm Allen Key (for M6 screws pulley attachment)
- G. 6mm Allen Key (for M8 screws)
- H. Pencil-Style Tension Gauge (for belt tensioning)
- i. 4 x M6 Flat Washers (Optional)

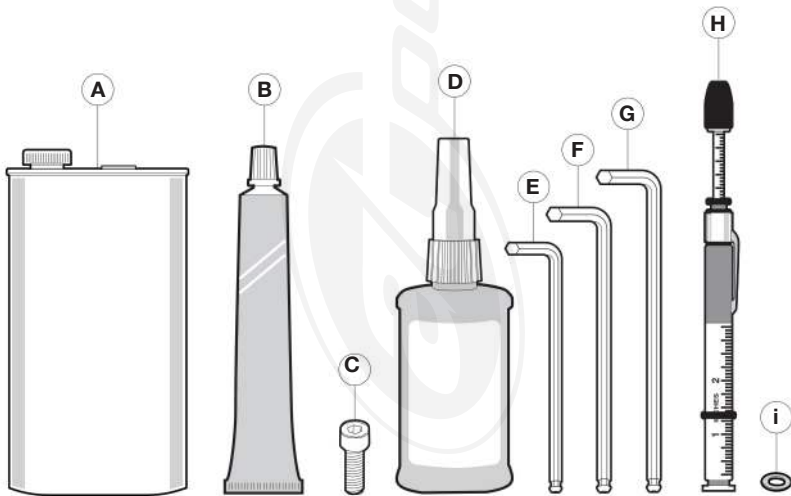

# General Dry Oil Sump Pan Installation

---

AT Power dry sump systems and oil pumps are assembled in a clean environment. However, upon removing the parts from their shipping packaging, ensure they are clean and free from any packaging material.

Remove the existing wet sump pan from the engine block and, where applicable, any windage tray and OEM oil pump. Before installing the dry sump pan onto the underside of the cylinder block, confirm that the mating surface is clean and free from debris or residual sealant. Clean both surfaces with brake cleaner or degreaser.

**Warning:** Any old gasket sealant left inside the crank case can cause catastrophic engine failure.

Apply a suitable RTV silicone sealant evenly around the oil pan joint face before fitting the oil pan. Fit and secure the pan with suitable fixings as listed on the schematic diagram on the following pages.

## 1. Select your AT Power Dry Sump Schematics

---

- 7..... Typical Belt Driven Sump System
- 8..... Ford 1.6L EcoBoost
- 9..... Ford Duratec
- 10.... Ford Sigma 2 Stage
- 11.... Ford Sigma 3 Stage
- 12.... Honda K20/24 Belt Driven
- 13.... Peugeot/Citroen EW10
- 14.... Peugeot/Citroen XU10
- 15.... Vauxhall/Opel X20XE

## 2. Then proceed to:

---

- |                                   |  |
|-----------------------------------|--|
| 16.... Crankshaft Pulley Assembly | 21.... Force/Deflection                                |
| 16.... Mounting the Pump          | 22.... Timing Belt Final Adjustments                   |
| 17.... Oil Pump Pulley Attachment | 23.... Oil Pump Pressure Relief Valve (PRV) Adjustment |
| 18.... Timing Belt Tension        |  |
| 19.... Timing Belt Installation   |  |
| 20.... Numerical Method For Belt  |  |

## Typical Belt Driven Dry Sump System

For general belt-driven dry sump kits, the following system configuration guide is recommended for 1.6L to 2.5L engines. Remove red caps when you're ready to install the oil lines.

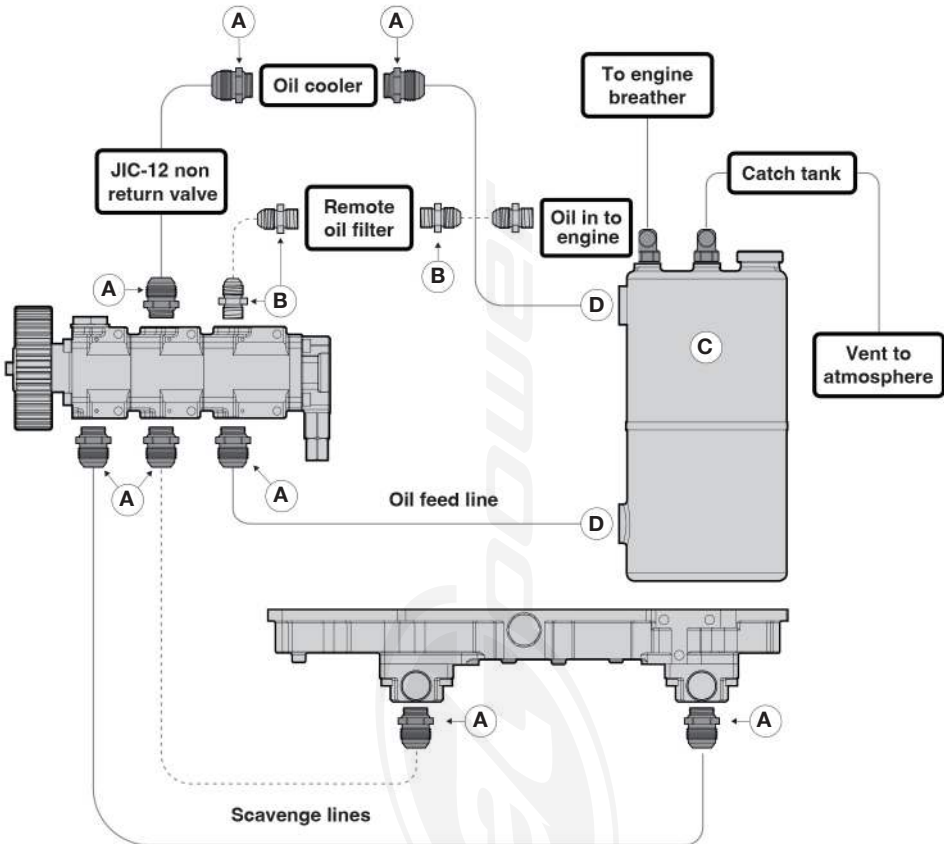

Items	Total	SKU
A. Fitting JIC-12	8	101-117-00001
B. Fitting JIC-10	4	101-117-00020
C. Dry sump easy clean oil tank:	1	
- 5L - (6.5" x 14-0")		101-134-00002
- 7L - (8.25" x 14-0") Typically for inside engine bay		101-134-00003
- 10.0L - (9.5" x 16-0") Typically for outside engine bay		101-134-00004
D. Oil tank fittings for:	2	
- 5L Tanks: M22 x 1.5 female threads		
- 7L & 10L Tanks: 1-5/16" x 12 TPI female threads		

# Ford Duratec (Intake Side Shown) Belt Driven Dry Sump System



This product has been tested up to a maximum of 9,000 RPM. Do not exceed this limit, as doing so will void your warranty.

Example system configuration

Date: 10/2025

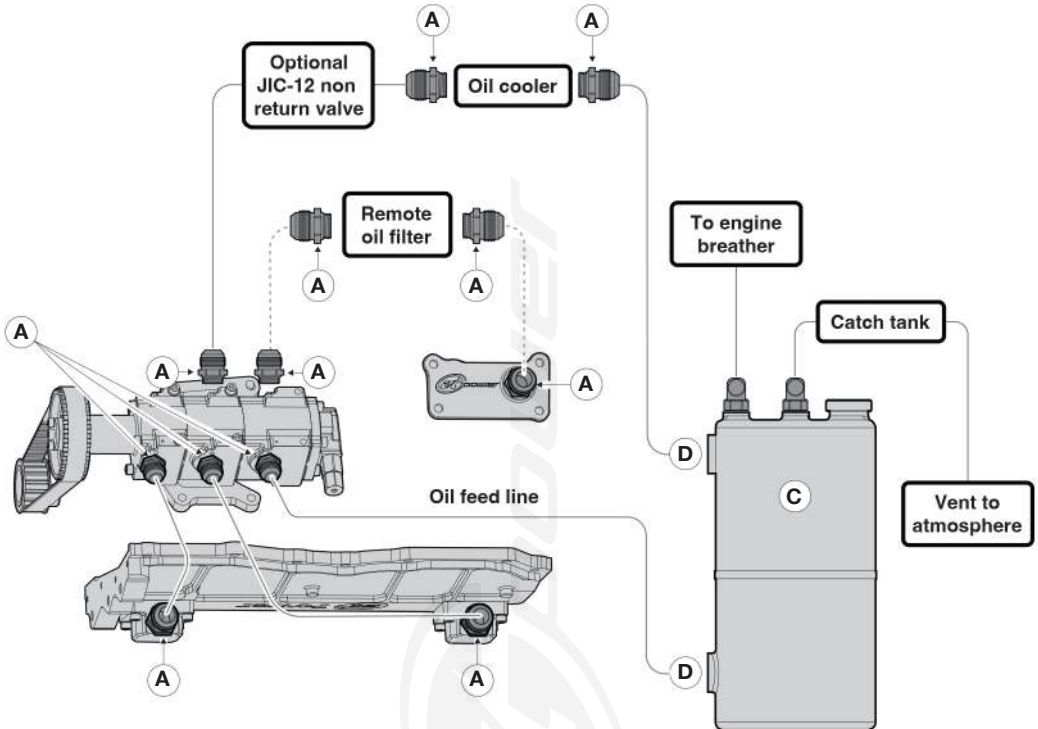

Items	Total	SKU
A. Fitting JIC-12 (x3 Supplied)	3/12	101-117-00001
B. Dry sump easy clean oil tank:	1	
- 5L - (6.5" x 14-0")		101-134-00002
- 7L - (8.25" x 14-0") <i>Typically for inside engine bay</i>		101-134-00003
- 10.0L - (9.5" x 16-0") <i>Typically for outside engine bay</i>		101-134-00004
C. Oil tank fittings for:	2	
- 5L Tanks: M22 x 1.5 female threads		
- 7L & 10L Tanks: 1-5/16" x 12 TPI female threads		

The sump pan requires M8 screws (16-18Nm Torque) to secure it to the engine block. Remove red caps when you're ready to install the oil lines.

Proceed to page 16.

# Ford 2.3L EcoBoost Belt Driven Dry Sump System



This product has been tested up to a maximum of 9,000 RPM. Do not exceed this limit, as doing so will void your warranty.

Example system configuration

Date: 10/2025

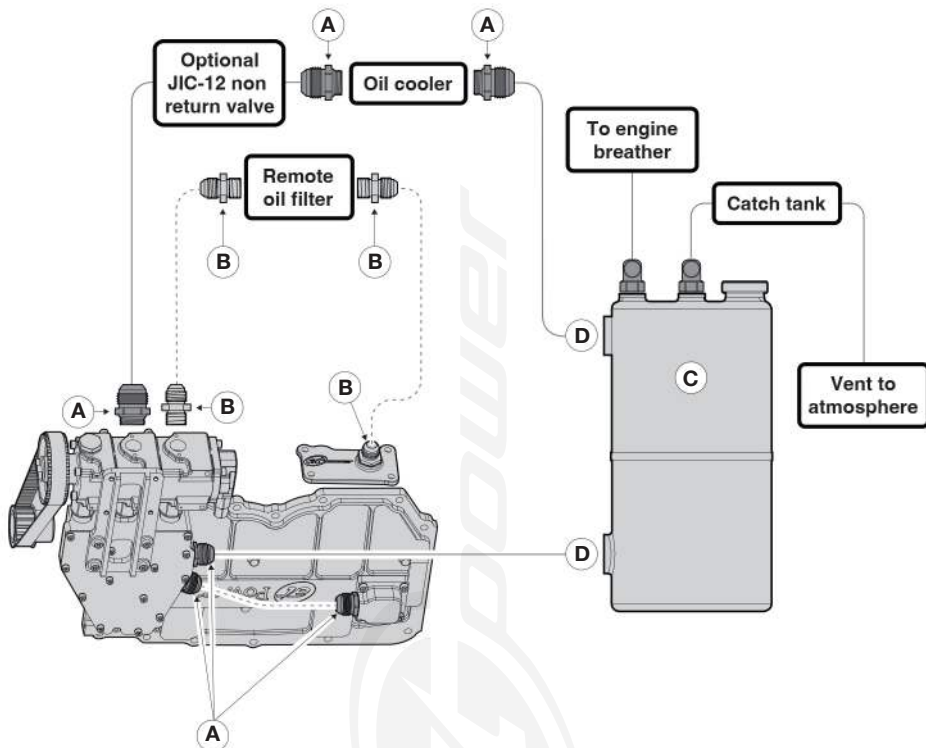

Items	Total	SKU
A. Fitting JIC-12 (x3 Supplied)	3/6	101-117-00001
B. Fitting JIC-10 (x1 Supplied)	1/4	101-117-00020
C. Dry sump easy clean oil tank:	1	
- 5L - (6.5" x 14-0")		101-134-00002
- 7L - (8.25" x 14-0") <i>Typically for inside engine bay</i>		101-134-00003
- 10.0L - (9.5" x 16-0") <i>Typically for outside engine bay</i>		101-134-00004
D. Oil tank fittings for:	2	
- 5L Tanks: M22 x 1.5 female threads		
- 7L & 10L Tanks: 1-5/16" x 12 TPI female threads		

The sump pan requires M8 screws (16-18Nm Torque) to secure it to the engine block. Remove red caps when you're ready to install the oil lines.

Proceed to page 16.

# Ford Sigma 2 Stage (Intake Side Shown) Belt Driven Dry Sump System



This product has been tested up to a maximum of 9,000 RPM. Do not exceed this limit, as doing so will void your warranty.

Example system configuration

Date: 10/2025

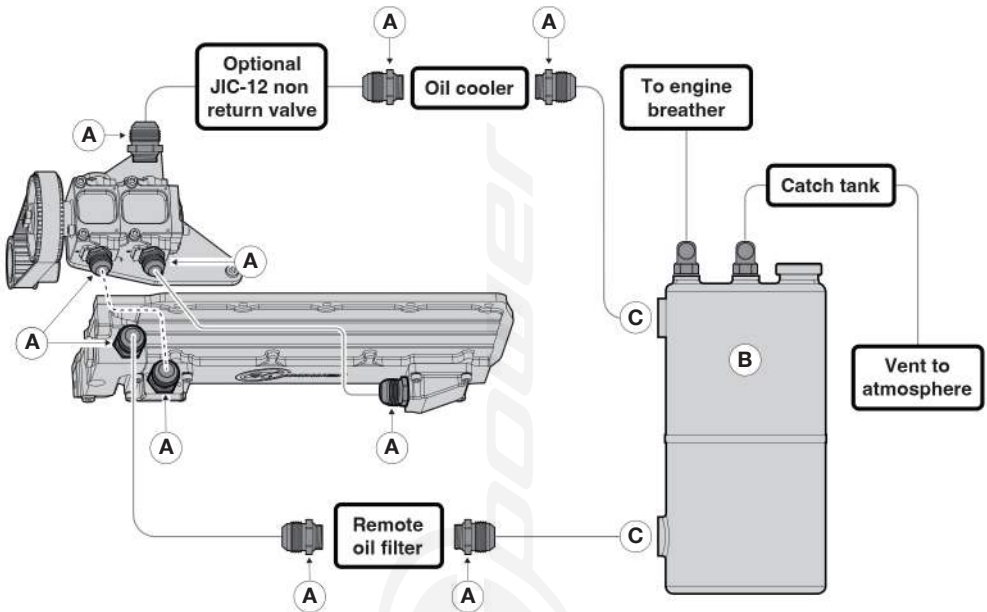

Items	Total	SKU
A. Fitting JIC-12 (x3 Supplied)	3/10	101-117-00001
B. Dry sump easy clean oil tank:	1	
- 5L - (6.5" x 14-0")		101-134-00002
- 7L - (8.25" x 14-0") <i>Typically for inside engine bay</i>		101-134-00003
- 10.0L - (9.5" x 16-0") <i>Typically for outside engine bay</i>		101-134-00004
C. Oil tank fittings for:	2	
- 5L Tanks: M22 x 1.5 female threads		
- 7L & 10L Tanks: 1-5/16" x 12 TPI female threads		

The sump pan requires M8 screws (16-18Nm Torque) to secure it to the engine block. Remove red caps when you're ready to install the oil lines.

Proceed to page 16.

# Ford Sigma 3 Stage (Intake Side Shown) Belt Driven Dry Sump System



This product has been tested up to a maximum of 9,000 RPM. Do not exceed this limit, as doing so will void your warranty.

Example system configuration

Date: 10/2025

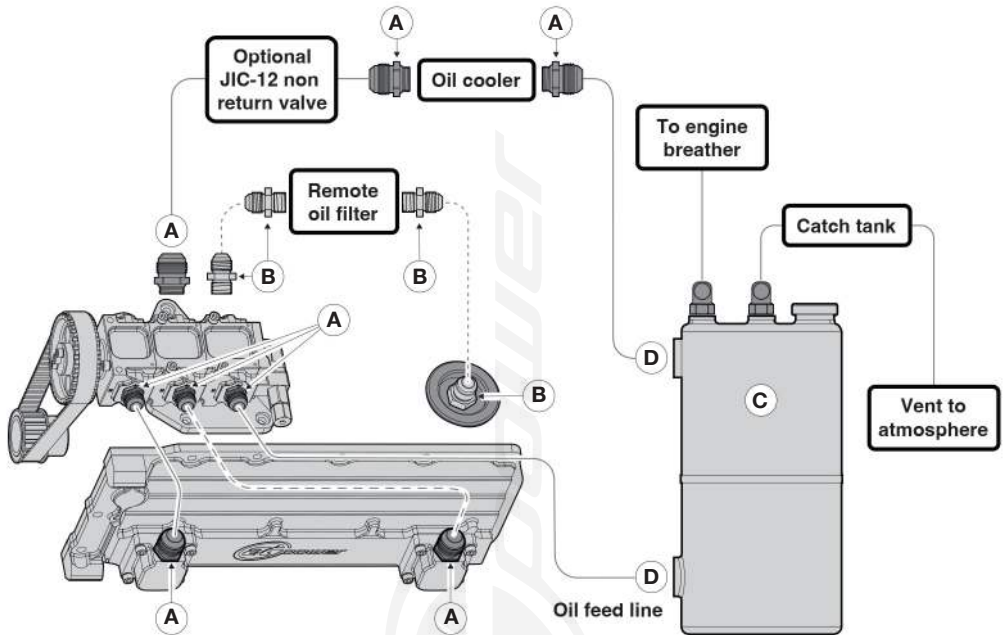

Items	Total	SKU
A. Fitting JIC-12 (x2 Supplied)	2/8	101-117-00001
B. Fitting JIC-10 (x1 Supplied)	1/4	101-117-00020
C. Dry sump easy clean oil tank:	1	
- 5L - (6.5" x 14-0")		101-134-00002
- 7L - (8.25" x 14-0") <i>Typically for inside engine bay</i>		101-134-00003
- 10.0L - (9.5" x 16-0") <i>Typically for outside engine bay</i>		101-134-00004
D. Oil tank fittings for:	2	
- 5L Tanks: M22 x 1.5 female threads		
- 7L & 10L Tanks: 1-5/16" x 12 TPI female threads		

The sump pan requires M8 screws (16-18Nm Torque) to secure it to the engine block. Remove red caps when you're ready to install the oil lines.

Proceed to page 16.

# Honda K20 (Intake Side Shown) Belt Driven Dry Sump System

**!** This product has been tested up to a maximum of 9,500 RPM. Do not exceed this limit, as doing so will void your warranty.

Example system configuration

Date: 10/2025

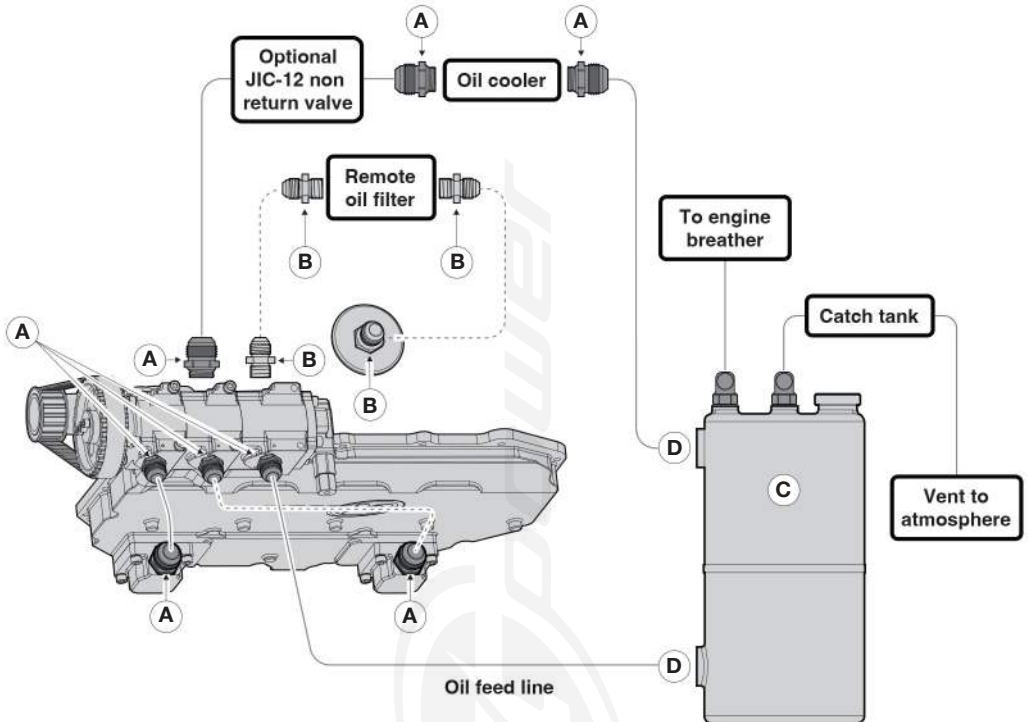

Items	Total	SKU
A. Fitting JIC-12 (x2 Supplied)	2/8	101-117-00001
B. Fitting JIC-10 (x1 Supplied)	1/4	101-117-00020
C. Dry sump easy clean oil tank:	1	
- 5L - (6.5" x 14-0")		101-134-00002
- 7L - (8.25" x 14-0") <i>Typically for inside engine bay</i>		101-134-00003
- 10.0L - (9.5" x 16-0") <i>Typically for outside engine bay</i>		101-134-00004
D. Oil tank fittings for:	2	
- 5L Tanks: M22 x 1.5 female threads		
- 7L & 10L Tanks: 1-5/16" x 12 TPI female threads		

The sump pan requires M6 screws (10-12Nm Torque) to secure it to the engine block. Remove red caps when you're ready to install the oil lines.

Proceed to page 16.

# Peugeot/Citroën EW10 Belt Driven Dry Sump System



This product has been tested up to a maximum of 8,500 RPM. Do not exceed this limit, as doing so will void your warranty.

Example system configuration

Date: 10/2025

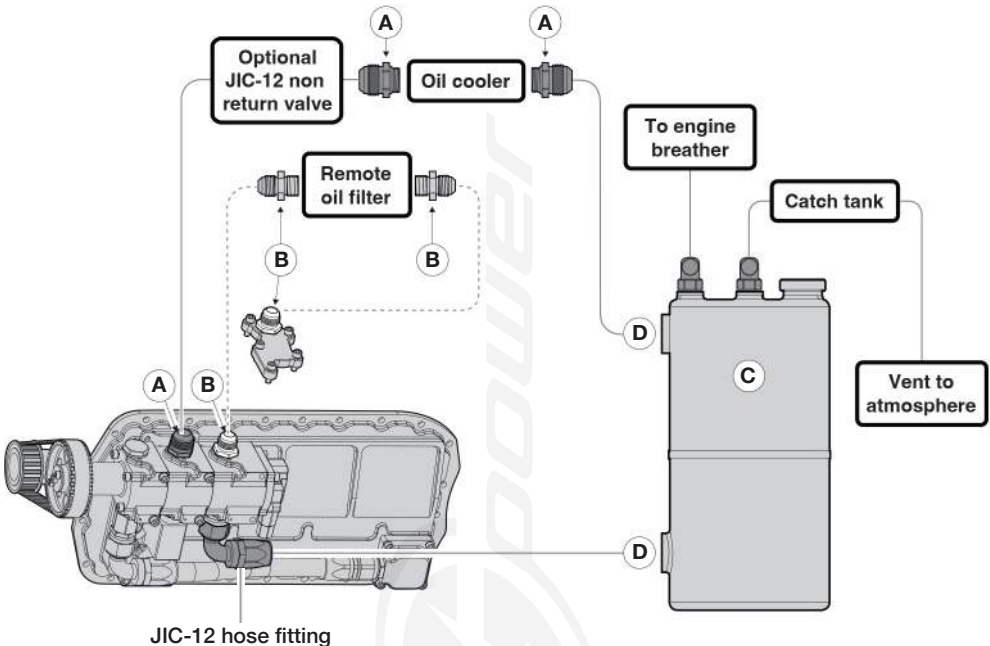

Items	Total	SKU
A. Fitting JIC-12 (x1 Supplied)	1/3	101-117-00001
B. Fitting JIC-10 (x2 Supplied)	2/4	101-117-00020
C. Dry sump easy clean oil tank:	1	
- 5L - (6.5" x 14-0")		101-134-00002
- 7L - (8.25" x 14-0") <i>Typically for inside engine bay</i>		101-134-00003
- 10.0L - (9.5" x 16-0") <i>Typically for outside engine bay</i>		101-134-00004
D. Oil tank fittings for:	2	
- 5L Tanks: M22 x 1.5 female threads		
- 7L & 10L Tanks: 1-5/16" x 12 TPI female threads		

The sump pan requires M8 screws (16-18Nm Torque) to secure it to the engine block. Remove red caps when you're ready to install the oil lines.

Proceed to page 16.

# Peugeot/Citroën XU10 Belt Driven Dry Sump System



This product has been tested up to a maximum of 8,500 RPM. Do not exceed this limit, as doing so will void your warranty.

Example system configuration

Date: 10/2025

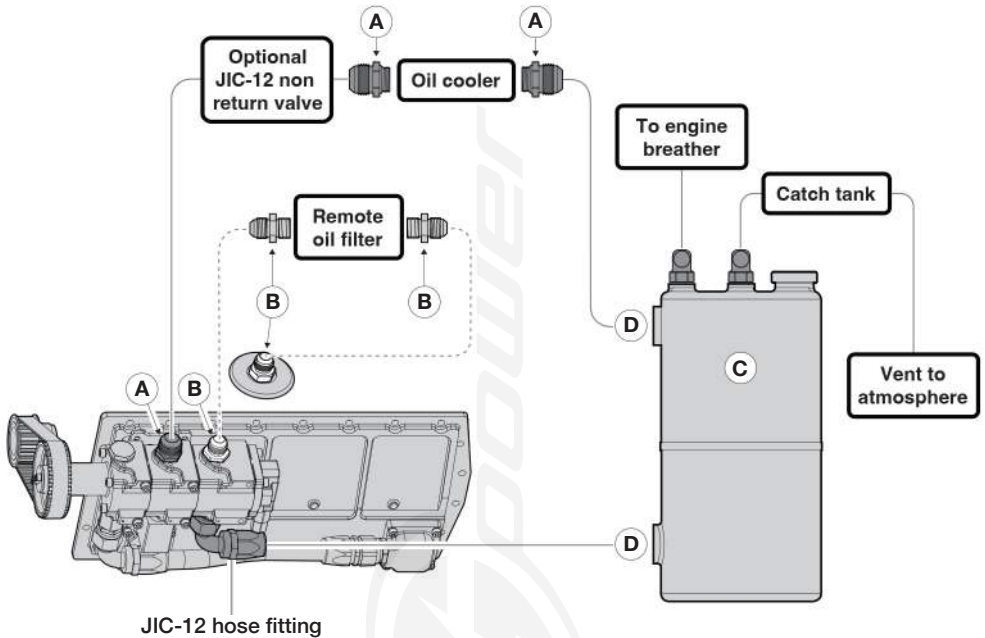

Items	Total	SKU
A. Fitting JIC-12 (x1 Supplied)	1/3	101-117-00001
B. Fitting JIC-10 (x2 Supplied)	2/4	101-117-00020
C. Dry sump easy clean oil tank:	1	
- 5L - (6.5" x 14-0")		101-134-00002
- 7L - (8.25" x 14-0") <i>Typically for inside engine bay</i>		101-134-00003
- 10.0L - (9.5" x 16-0") <i>Typically for outside engine bay</i>		101-134-00004
D. Oil tank fittings for:	2	
- 5L Tanks: M22 x 1.5 female threads		
- 7L & 10L Tanks: 1-5/16" x 12 TPI female threads		

The sump pan requires M8 screws (16-18Nm Torque) to secure it to the engine block. Remove red caps when you're ready to install the oil lines.

Proceed to page 16.

# Vauxhall Opel X20XE/C20XE (Exhaust Side Shown) Belt Driven Dry Sump System



This product has been tested up to a maximum of 8,500 RPM. Do not exceed this limit, as doing so will void your warranty.

Example system configuration

Date: 10/2025

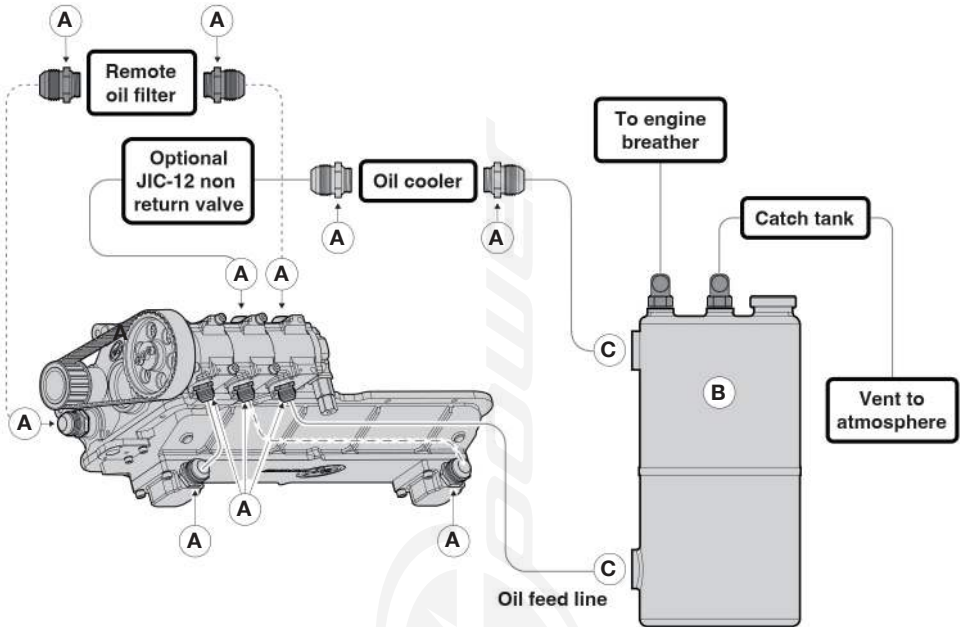

Items	Total	SKU
A. Fitting JIC-12 (x3 Supplied)	3/12	101-117-00001
B. Dry sump easy clean oil tank:	1	
- 5L - (6.5" x 14-0")		101-134-00002
- 7L - (8.25" x 14-0") <i>Typically for inside engine bay</i>		101-134-00003
- 10.0L - (9.5" x 16-0") <i>Typically for outside engine bay</i>		101-134-00004
C. Oil tank fittings for:	2	
- 5L Tanks: M22 x 1.5 female threads		
- 7L & 10L Tanks: 1-5/16" x 12 TPI female threads		

The sump pan requires M6 screws (10-12Nm Torque) to secure it to the engine block. Remove red caps when you're ready to install the oil lines.

Immediately after fitting the pan, fit the front cover on this x20xe engine.

Proceed to page 16.

## Crankshaft Pulley Assembly

---

Before installation, if you are using a *blank* AT Power crankshaft pulley and pulley rings, they must be securely welded together to ensure proper belt alignment.

Machine the crankshaft blank to your specified dimensions. Position the guide rings on the crank pulley and secure each ring with four evenly spaced short seam welds on the outside, as shown. Once complete, we recommend to zinc plate the pulley to ensure corrosion protection.

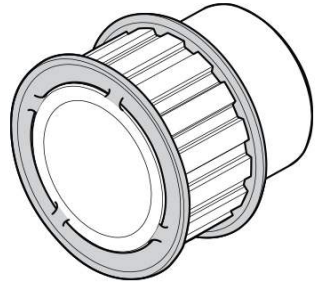

If the crankshaft pulley is provided by AT Power, it should be mounted onto the crankshaft using the original OEM crank bolt. Ensure the bolt is tightened to the manufacturer's specified torque setting. In certain cases the crank bolt will have a thick washer, this should be removed before fitting.

## Mounting the Pump

---

Securely mount the pump using appropriate M6 screws, tightened to 10–12 Nm.

### Parts Required For

---

- 1 Stage Pumps - 2 x M6 Screws
- 2, 3 and 4 Stage Pumps - 4 x M6 Screws

*Drawing may vary from product*

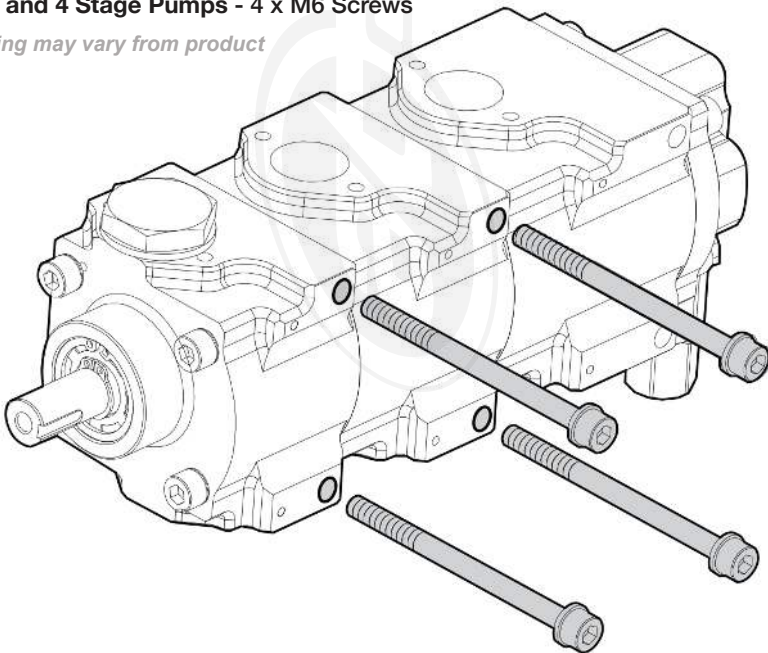

# Oil Pump Pulley Attachment

---

## Parts Supplied

---

- A. Key
- B. Oil Pump Shaft
- C. Oil Pump Pulley Wheel
- D. 3 Hole Locking Washer
- E. 2 x M5 Screws
- F. 2 x M5 Schnorr Washers
- G. M6 Screw
- H. M6 Schnorr Washer

## Parts Required

---

- Loctite 242 or equivalent
- 4mm Allen Key
- 5mm Allen Key

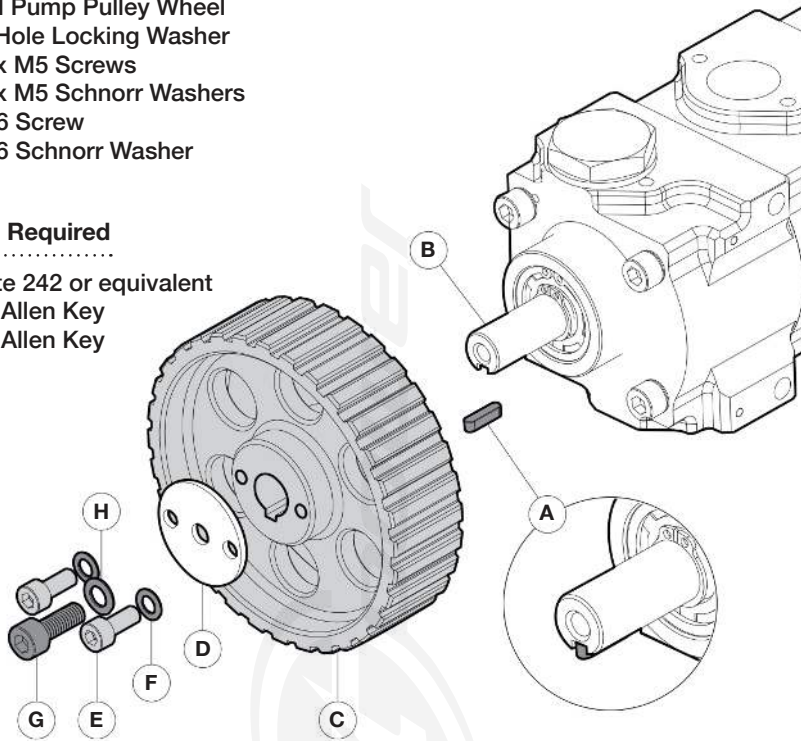

1. Attach the key (A) into the oil pump shaft (B) securely before proceeding.
2. Position the pulley (C) onto the oil pump shaft, making sure the key is properly aligned into the keyway on the pulley. Place the locking washer (D) over the pulley, then secure it using 2 x M5 screws (E) with M5 Schnorr flat washers (F). Apply Loctite to the screws before tightening them to a torque of 8-10 Nm.
3. Insert the M6 screw (G) with the M6 Schnorr washer (H) to secure the center and use Loctite to lock it in place. Torque it to 10-12 Nm whilst the glue has not yet set.

## Timing Belt Tensioning

---

Unsure what timing belt length you need? Simply wrap a piece of string around the pulleys, lay it flat, and measure it - this will give you the required L-Belt length. For compatible timing belts, please visit our website. For correct tensioning procedures, refer carefully to the following pages.

Proper timing belt tension is critical. Insufficient tension can cause the belt to ratchet (skip teeth). A loosely tensioned belt behaves like a slack string, which can snap under high torque as the excessive stress surpasses its design limits.

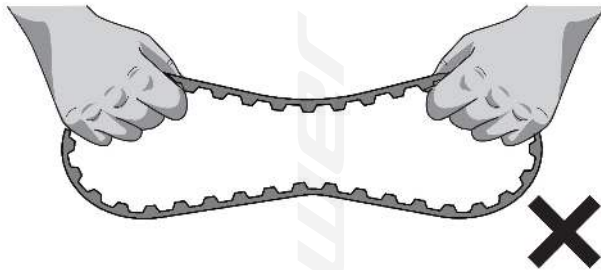

Excessive tension may lead to premature wear or damage to bearings, shafts, and other drive components, significantly reducing the belt's lifespan.

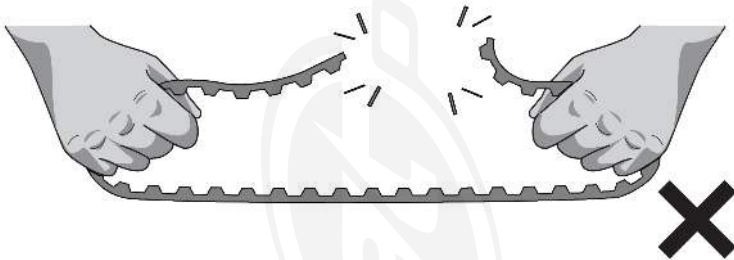

In contrast, a properly tensioned belt, like a taut string, can withstand strong forces without failure. The ideal tension is the lowest possible tension that allows the belt to transmit the required mechanical power without skipping teeth under full load:

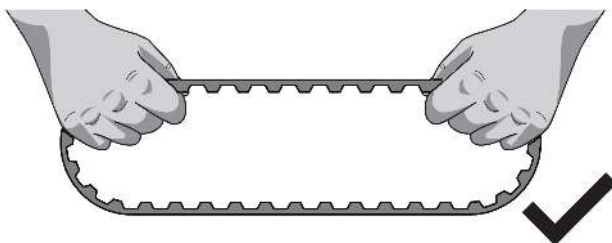

## Timing Belt Installation

Ensure the pulleys are properly aligned both parallel and angularly for smooth operation - if they're misaligned, the timing belt may slip off or come loose during use.

Carefully inspect the timing belt for any signs of damage. If there is damage, do not proceed with the installation.

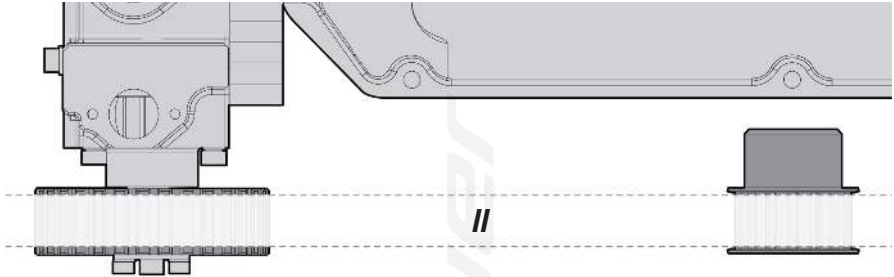

To install and properly tension the timing belt, begin by reducing the centre distance (A) between the pulleys or releasing the tensioning idler to allow for easy belt placement.

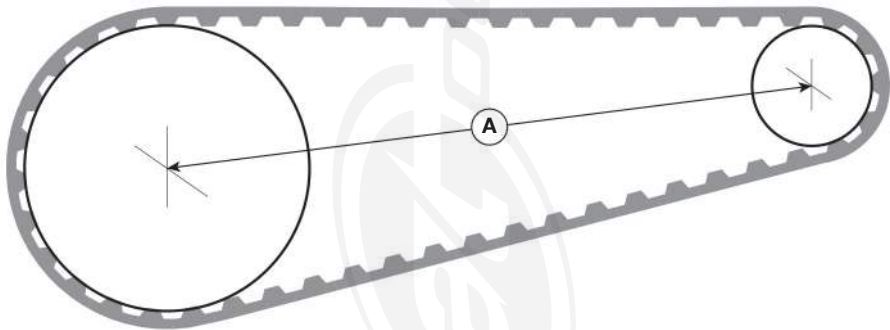

Carefully position the belt onto the pulley, ensuring that the teeth are fully seated in the pulley grooves - do not pry the belt onto the pulleys, this can cause damage.

Once the belt is in place, increase the centre distance (A) or adjust the tensioning idler to remove any slack. Before working out the correct tension, manually rotate the drive system to confirm the belt teeth remain properly engaged in the grooves.

AT Power recommends the 'Numerical Method' for verifying correct deflection and belt tension.

# Numerical Method For Belt Force/Deflection

The numerical method involves measuring the deflection of the timing belt under a known force to achieve the required tension. The target tension is determined by two key values: Deflection Force and Deflection Distance.

## Timing Belt Tensioning Procedure

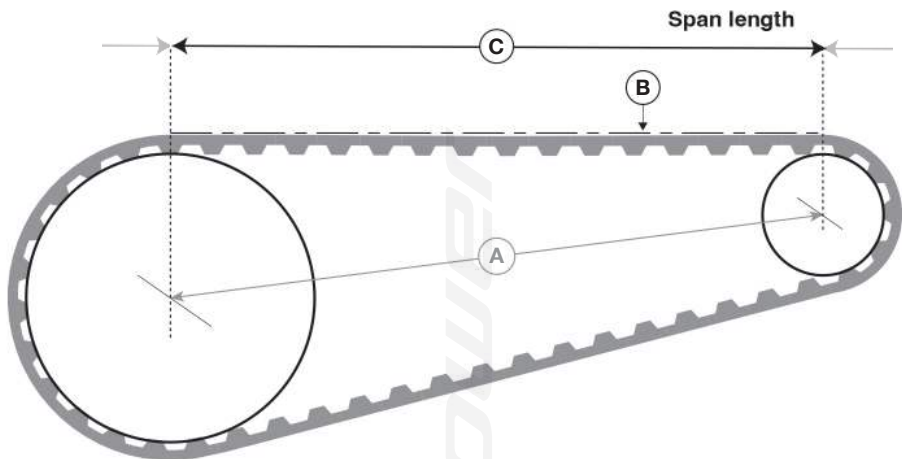

Lay a straight edge (B) across the top of the timing belt.

Use this calculation to work out the required Deflection distance:

$$\frac{1}{64} \times \text{Span length (C)} = \text{Deflection Distance (D)}$$

Measured from Pulley Centres

## Pencil-Style Tension Gauge

SKU: 101-127-00075

Set the large O-ring on the pencil-style tension gauge (pictured) to the Deflection Distance (D) measurement above. Convert all measurements to match the gauge used.

Set the small O-ring on the plunger to zero (E). This measures the Deflection Force in pounds (lbs).

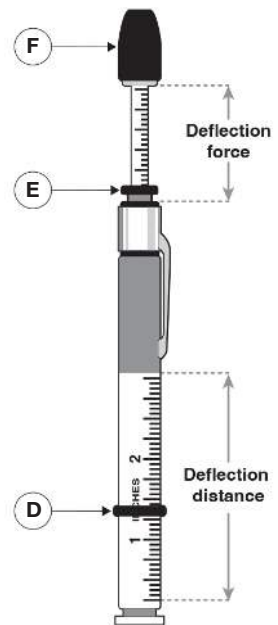

At the centre of the span length (C), apply force using a pencil-style tension gauge, ensuring the force is applied perpendicular to the span with the rubber plunger (F) pressed against your palm.

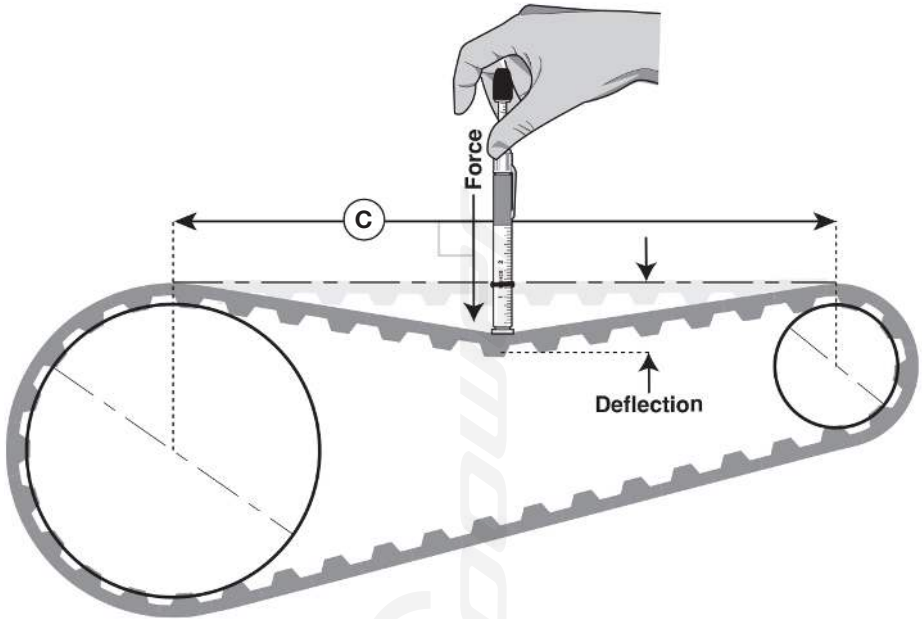

Deflect the belt until the bottom of the large O-ring (D) is level with the bottom of the straight edge. Release the pressure and note the deflection force indicated by the small O-ring (E).

Identify the correct deflection force required in this grid to achieve proper belt tension.

Belt Pitch	Belt Width	Deflection Force		
'L' section 3/8" pitch	1/2"	7oz	198g	1.95N
	3/4"	11oz	312g	3.06N
	1"	1lb	397g	4.45N

For adjusting, see next page.

## Timing Belt Final Adjustments

---

After these pre-tensioning steps, several methods can be used to verify that the final tension is correct. If the measured force is less than the required deflection force, increase the centre distance (A) to add tension.

If the measured force is greater than the required deflection force, reduce the centre distance to relieve tension.

After properly tensioning the timing belt, secure the centre distance adjustments and verify that the pulleys remain correctly aligned.

 After approximately 8 hours of operation, recheck both the timing belt tension and sprocket alignment to ensure the drive has not shifted.

### AT Power Belt Driven Dry Sump Kits

---

For all belt-driven dry sump kits produced by AT Power that do not include a belt tensioning facility, 4 x M6 flat washers (F) can be added between the oil pump and the mounting bracket to achieve the required belt tension, if necessary.

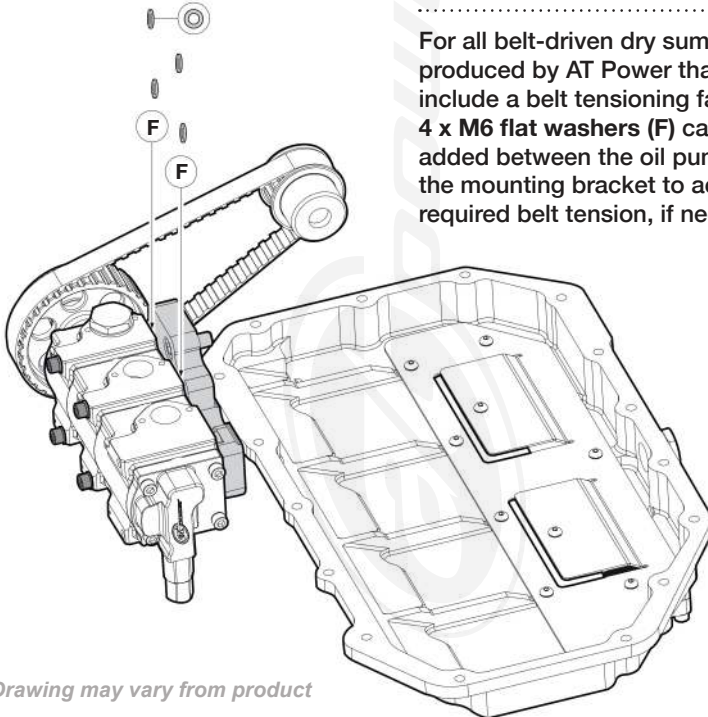

*Drawing may vary from product*

Following this procedure ensures optimal timing belt tension, maximising performance and longevity.

After installing the dry sump system, prime all feed lines, the engine, and the pump with oil before starting. Remove the spark plugs and turn the engine over with the starter motor to do this.

## Oil Pump Pressure Relief Valve (PRV) Adjustment

The Pressure Relief Valve (PRV) is a self-contained system and does not require any parts to be removed or loosened for adjustment.

If you have a pressure pump, you will need a 4mm Allen key to adjust it. There is a maximum of 15 turns between the minimum and maximum pressure settings.

AT Power has preset the pump to 7 turns in (the midpoint). Each pump is tested at this preset, and a unique datasheet is generated from its performance.

### Parts Required

4mm Allen Key

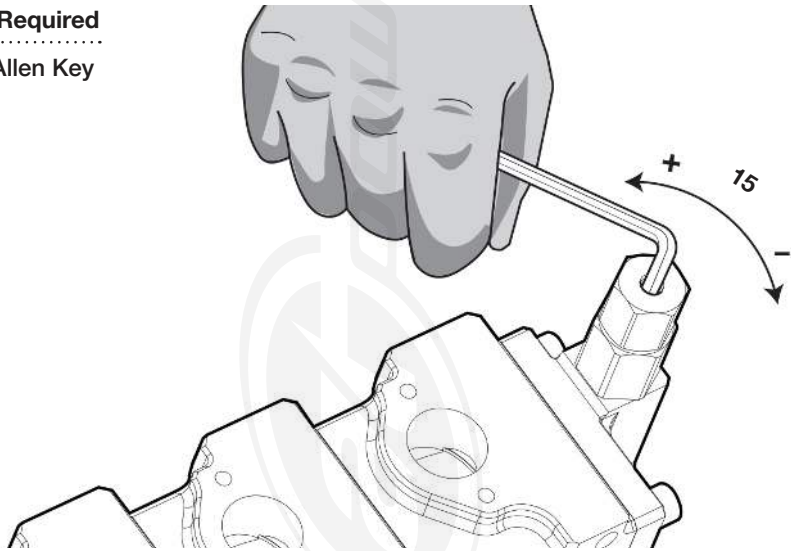

*Drawing may vary from product*

Turning clockwise will reduce pressure. At minimum pressure, the PRV will lock and no longer rotate.

Turning counterclockwise will increase pressure. At maximum pressure, the PRV will continue to rotate, but the pressure will not increase further.

For optimal results, it is recommended to make the final adjustment when the engine has reached operating temperature and the oil has reached its lowest viscosity.



**Tag us in your engine build!**



**Connect via WhatsApp**

**[www.atpower.com](http://www.atpower.com)**

**Tel: +44 1953 875800**

**[info@atpowerthrottles.com](mailto:info@atpowerthrottles.com)**

**S-CAN 3D Ltd, Unit 10b Bunns Bank Ind Est,  
Attleborough, Norfolk, NR17 1QD, United Kingdom**

