

ISOMETRIC VIEW

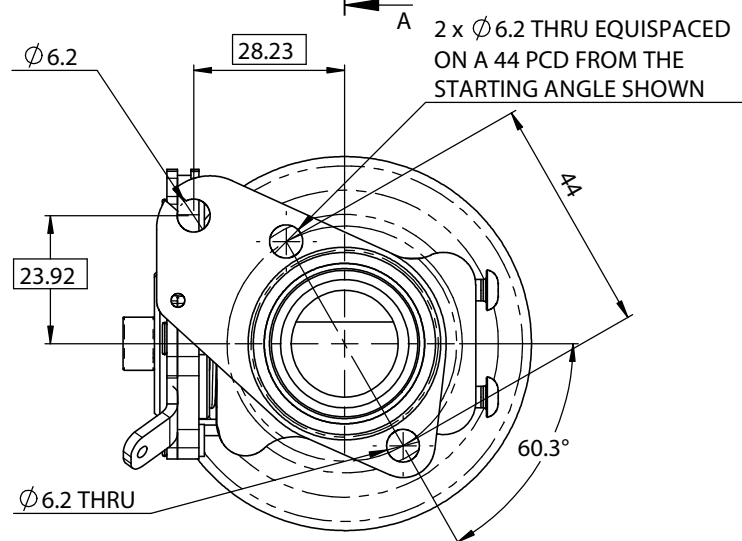

SECTION A-A
 $\phi 19.99$
 $\phi 19.92$



S-CAN 3D Ltd
 Bunn's Bank Ind Est
 Attleborough NR17 1QD

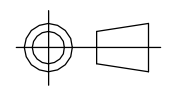

THIRD ANGLE PROJECTION

SCALE 1:1 WEIGHT 0.3 kg

DRAWN- S.HOW

DATE- 06/06/18

CHECKED - S.HOW

APPROVED - A.CLIFTON

UNLESS OTHERWISE STATED:
 DIMENSIONS IN MILLIMETRES
 TOLERANCES: LINEAR ± 0.1 ANGULAR $\pm 0.5^\circ$
 SURFACE FINISH $\sqrt{\text{V}}$ = $\sqrt{\text{V}}$
 DRAWING STANDARDS TO ATQS 6003
 DATE FORMAT: DD/MM/YY

THIS DESIGN IS THE PROPERTY OF
 S-CAN 3D LTD AND MUST NOT BE
 REPRODUCED OR COMMUNICATED
 WITHOUT AUTHORITY

CAD PLOT
 DO NOT
 SCALE

MATERIAL	SEE COMPONENT PARTS
FINISH	SEE COMPONENT PARTS
DRAWING TITLE	ASSY - ATP - FORMULA STUDENT - 28MM - 20MM RESTRICTOR
DRAWING NUMBER	102-102-00010 + 102-119-00003