

CABLE PULL TO THE RIGHT SIDE
 SELECT TPS SIDE
 (VARIOHM TPS ON RGHT SIDE PICTURED)

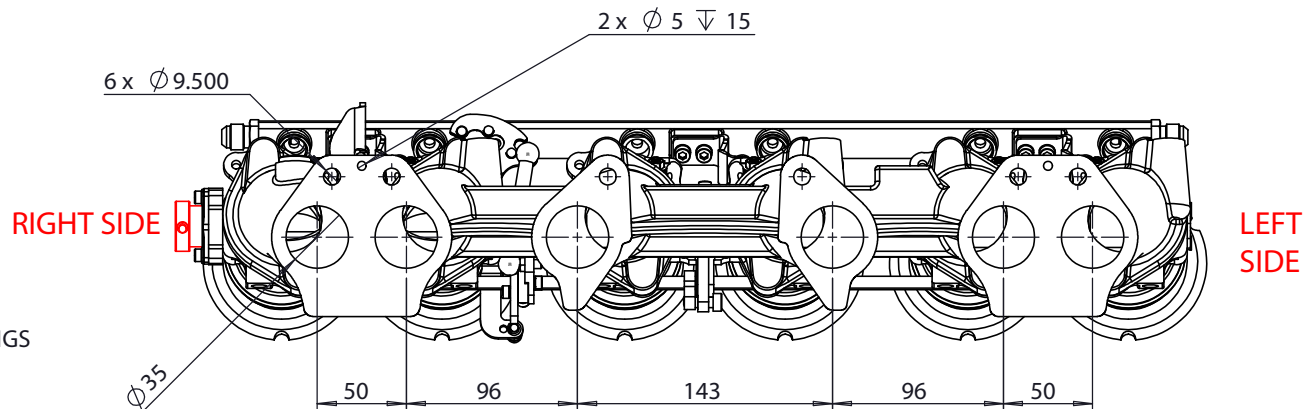

VIEW ON MATING CYLINDER HEAD FACE

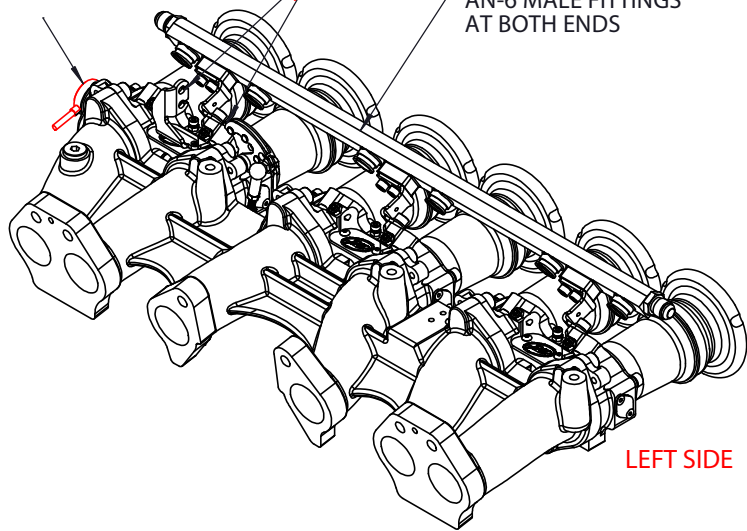

S-CAN 3D Ltd
 Bunn's Bank Ind Est
 Attleborough NR17 1QD

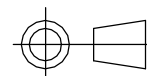

THIRD ANGLE PROJECTION

SCALE 1:3 WEIGHT 6099.283 kg

DRAWN- S.HOW

DATE- 15/11/23

CHECKED- S.HOW

APPROVED- A.CLIFTON

MATERIAL

SEE COMPONENT PARTS

FINISH

SEE COMPONENT PARTS

DRAWING TITLE

ASSY - THROTTLES - DATSUN
 240/260 & 280Z - 70 EXT X 40
 RAMS - RIGHT PULL

DRAWING NUMBER

102-102-00480

UNLESS OTHERWISE STATED:
 DIMENSIONS IN MILLIMETRES
 TOLERANCES: LINEAR ±0.1 ANGULAR ±0.5°
 SURFACE FINISH √ = √
 DRAWING STANDARDS TO ATQS 6003
 DATE FORMAT: DD/MM/YY

THIS DESIGN IS THE PROPERTY OF
 S-CAN 3D LTD AND MUST NOT BE
 REPRODUCED OR COMMUNICATED
 WITHOUT AUTHORITY

CAD PLOT
 DO NOT
 SCALE