

SECTION B-B

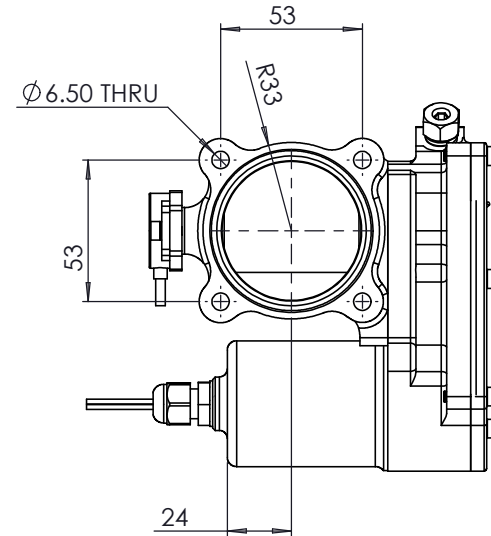

- NOTE:
 1. FOR TPS PIN OUT DETAIL SEE TPS DATA SHEET
 2. FOR MOTOR:
 + = RED
 - = BLACK

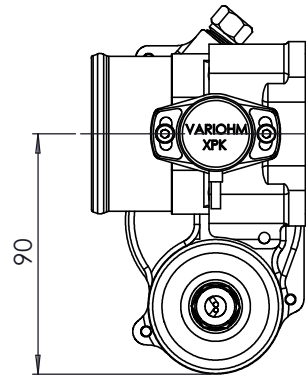
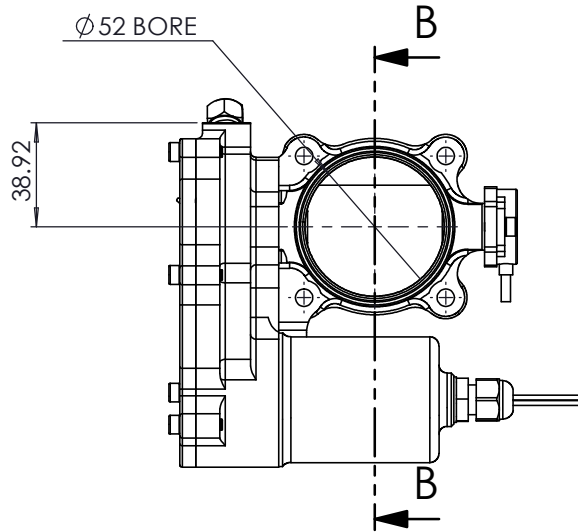

S-CAN 3D Ltd
 Bunn's Bank Ind Est
 Atleborough NR17 1QD

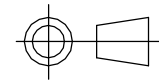

THIRD ANGLE PROJECTION
 SCALE 1:2 WEIGHT 0.9 kg

DRAWN- S.HOW
 DATE - 14/06/21

CHECKED - S.HOW
 APPROVED - A.CLIFTON

UNLESS OTHERWISE STATED:
 DIMENSIONS IN MILLIMETRES
 TOLERANCES: LINEAR ± 0.1 ANGULAR ± 0.5°
 SURFACE FINISH ✓ = ✓
 DRAWING STANDARDS TO ATQS 6003
 DATE FORMAT: DD/MM/YY

THIS DESIGN IS THE PROPERTY OF
 S-CAN 3D LTD AND MUST NOT BE
 REPRODUCED OR COMMUNICATED
 WITHOUT AUTHORITY

CAD PLOT
 DO NOT
 SCALE

MATERIAL	SEE COMPONENT PARTS
FINISH	SEE COMPONENT PARTS
DRAWING TITLE	DBW SINGLE THROTTLE - 52 BORE- 58 DIA HOSE INLET
DRAWING NUMBER	102-106-00057