

SECTION B-B

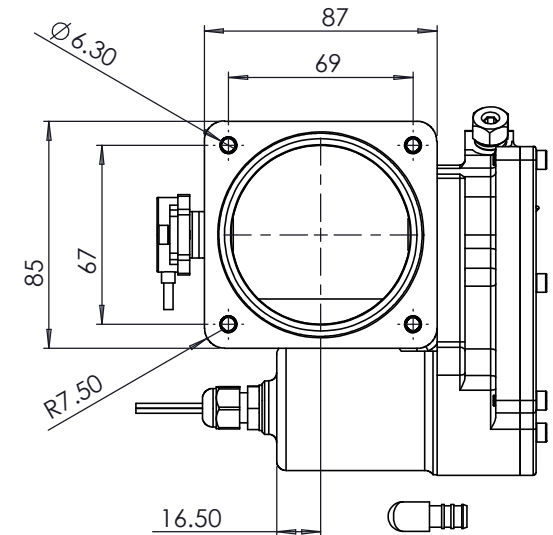

NOTE:
 1. FOR TPS PIN OUT DETAIL SEE TPS DATA SHEET.
 2. FOR MOTOR :
 + = RED
 - = BLACK



S-CAN 3D Ltd
 Bunn's Bank Ind Est
 Attleborough NR17 1QD

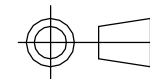

THIRD ANGLE PROJECTION

SCALE 1:2 WEIGHT 1.0 kg

DRAWN- S.HOW

DATE - 25/06/21

CHECKED - S.HOW

APPROVED - A.CLIFTON

UNLESS OTHERWISE STATED:
 DIMENSIONS IN MILLIMETRES
 TOLERANCES: LINEAR ±0.1 ANGULAR ±0.5°
 SURFACE FINISH √=√
 DRAWING STANDARDS TO ATQS 6003
 DATE FORMAT: DD/MM/YY

THIS DESIGN IS THE PROPERTY OF
 S-CAN 3D LTD AND MUST NOT BE
 REPRODUCED OR COMMUNICATED
 WITHOUT AUTHORITY

CAD PLOT
 DO NOT
 SCALE

MATERIAL

SEE COMPONENT PARTS

FINISH

SEE COMPONENT PARTS

DRAWING TITLE

DBW SINGLE THROTTLE - 67
 BORE- 76 DIA HOSE INLET -
 TOYOTA GT86

DRAWING NUMBER

102-106-00083

SHEET 2 OF 2 A3