

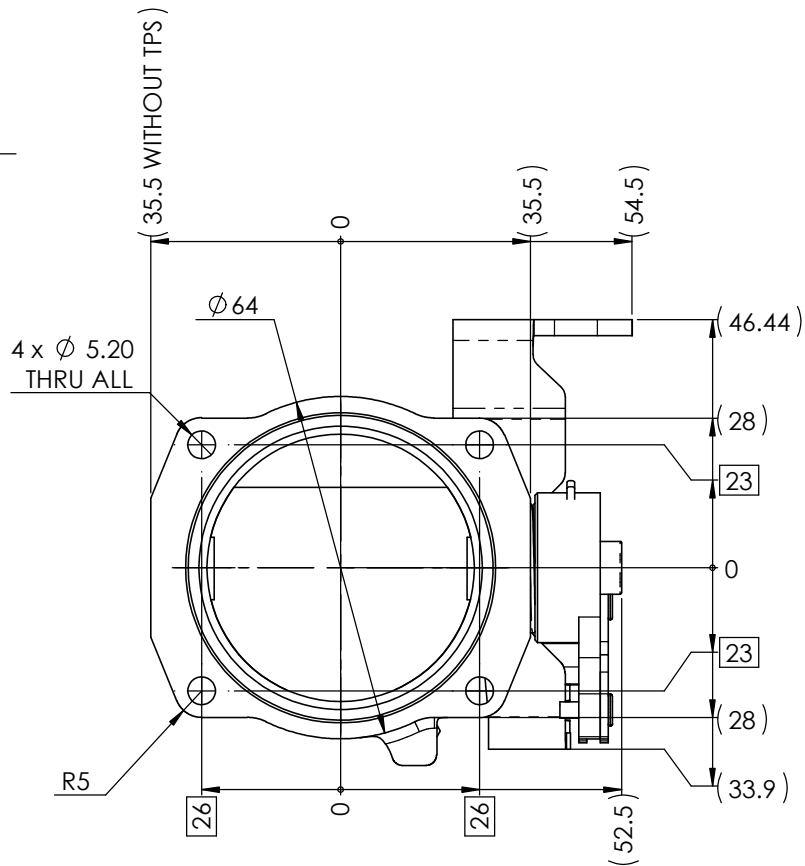
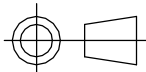

TPS SHAFT AND ADAPTOR TO BE SPECIFIED BY CUSTOMER



 S-CAN 3D Ltd Buns Bank Ind Est Attleborough NR17 1QD	 THIRD ANGLE PROJECTION	MATERIAL	SEE COMPONENT PARTS
		FINISH	SEE COMPONENT PARTS
UNLESS OTHERWISE STATED: DIMENSIONS IN MILLIMETRES TOLERANCES: LINEAR ± 0.1 ANGULAR ± 0.5° SURFACE FINISH √ = √ DRAWING STANDARDS TO ATQS 6003 DATE FORMAT: DD/MM/YY	SCALE 1:1	WEIGHT 0.3 kg	DRAWING TITLE
	DRAWN- S.HOW	DATE - 21/10/15	ASSY - SINGLE BORE - 50MM
THIS DESIGN IS THE PROPERTY OF S-CAN 3D LTD AND MUST NOT BE REPRODUCED OR COMMUNICATED WITHOUT AUTHORITY	CHECKED - S.HOW	DRAWING NUMBER	102-120-00007
	APPROVED - A.CLIFTON	CAD PLOT DO NOT SCALE	SHEET 2 OF 2 A3