

S-CAN 3D Ltd.

Unit 10b
Bunn's Bank Ind Est,
Attleborough
Norfolk
UK
NR17 1QD

Tel +44 (0)1953 857800
Email info@atpowerthrottles.com
Web www.atpower.com



Porsche 911 & 964 Brake Boost & Cold Idle Control

SKU 102-134-00018
DATASHEET REV002 27.2.25

Brake boost is required for hydraulic assisted brakes. IAC is required for cold idle control for use with Emerald ECU kit and AT Power supplied Motec ECU kit.

Assembly comes with all components to provide 3 setup options:

1. Brake boost only

Brake boost for hydraulic-assisted brakes.

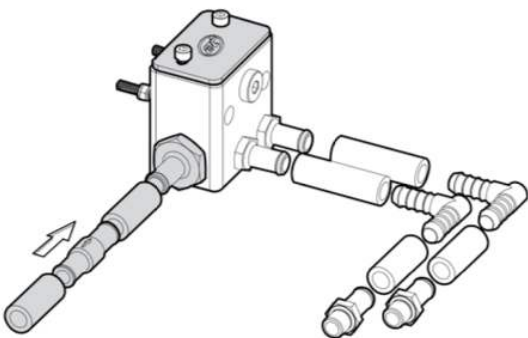

2. Idle air control (IAC) only

IAC is required for cold idle management with certain ECU kits.

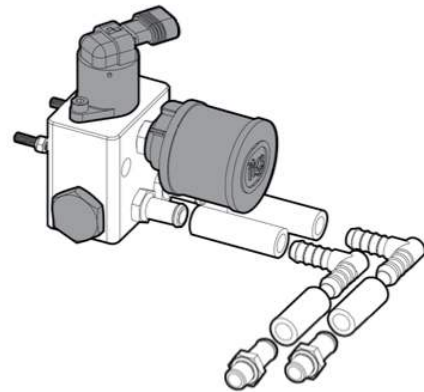

IAC Valve Pin Out

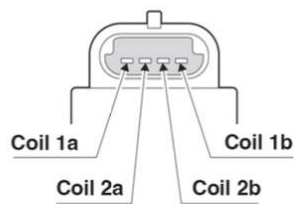

3. IAC and brake boost

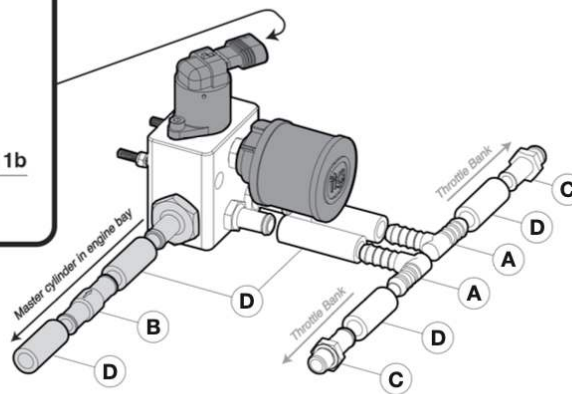

- A. 90° Elbow
- B. Non Return Valve
- C. Hose Tale Fitting
- D. 3m Silicon Hose (Cut to Length)

We reserve the right to modify this file's content or make technical changes without notice. For purchase orders, agreed terms take precedence. S-CAN 3D Ltd. accepts no liability for errors or omissions in this document.

