

S-CAN 3D Ltd.

Unit 10b
Bunn's Bank Ind Est,
Attleborough
Norfolk
UK
NR17 1QD

Tel +44 (0)1953 857800
Email info@atpowerthrottles.com
Web www.atpower.com



IAC PINOUT DETAIL

USING EMERALD K6 ECU

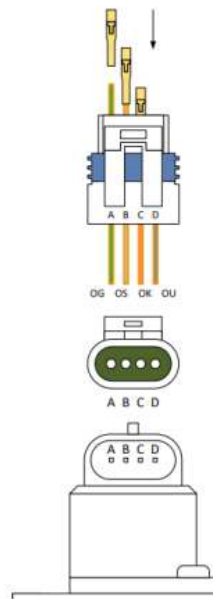

| Pin ID | Function | Colour | K6 ECU |
|--------|----------|---------------|--------|
| A | Coil 1a | Orange/ Green | 3 |
| B | Coil 2a | Orange/ Slate | 27 |
| C | Coil 2b | Orange/ Pink | 22 |
| D | Coil 1b | Orange/ Blue | 2 |

Open sequence 3 – 22 – 2 - 27

USING MOTEC M130 ECU

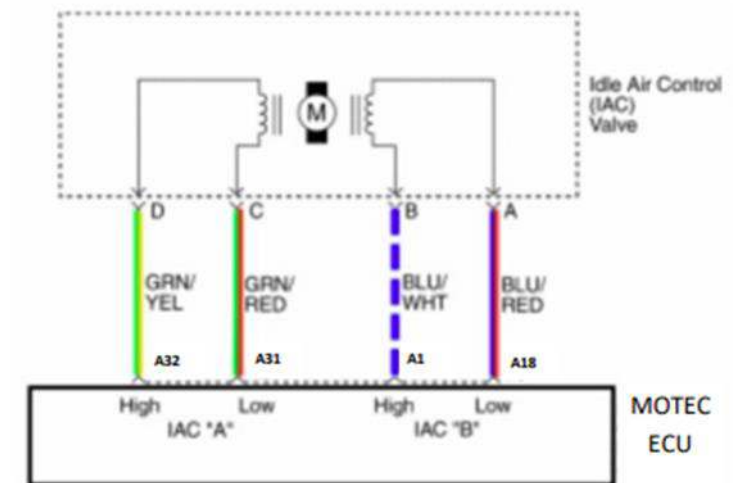

We reserve the right to make technical changes or modify the contents of this document without prior notice. With regards to purchase orders, the agreed particulars shall prevail. AT Power does not accept any responsibility whatsoever for potential errors or possible lack of information in this document.