

Fuel Injector Specs

IWP048 Fuel injector

5 hole – Cone spray, fuel injector



Description

This IWP048 "Pico" top feed injector is a production component with a multi hole 'cone' spray pattern and a wide range of applications for engines typically up to 30bhp per cylinder (depending on injection pressure)

The characteristics of the injector are a fast pulse response, high precision, high dynamic range and optimum fuel atomisation. These are achieved by a high performance ON-OFF actuating electromagnet with opposing expansion poles that moves an internal injector valve on high-precision ground cylindrical slides, and a high precision nozzle.

The injector has a stainless steel body, a fuel-resistant plastic connector, martensitic stainless steel internal valve and an electromagnet with a low carbon content stainless steel armature.

The electrical connection to the control unit is via a Mini-Timer plastic plug.



Technical Data

Performance - Typical

Flow..... Fully open
 At 3 bar 215 cc/min – 2.45g/s Cone
 – Inclusive 85% 24 ° Linearity
 range (at = 4 ms pulse) ± 4 % Max. fuel
 pressure 500 kPa Maximum
 duty cycle 90 % Operating
 temperature range..... -30...110 °C Vibration
 (peak) 30 g

Test conditions

Fluid..... N-Heptane
 density (@ 20°C) 0.684 kg/litre
 Ambient and fluid temperature 23 °C

Power supply..... 14 Vdc

Mechanical Characteristics

Height..... 47.2 mm
 Outside diameter (connector excluded) 15.3 mm
 Weight..... 35 g

Electrical Characteristics

Connector..... Mini-Timer 2 way
 Power supply..... 8 ÷ 16 Vdc
 Resistance 14.5 Ω
 Driver type..... ON-OFF

Electrical connections

PIN	Description
1	GND
2	+12 V

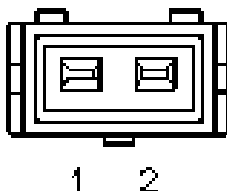

Spray Data

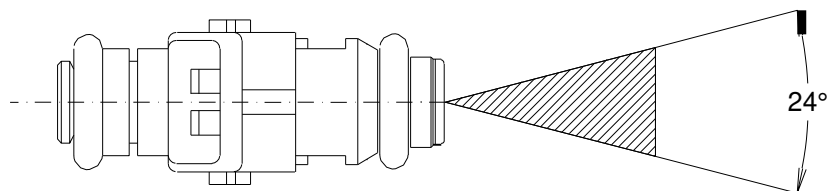

Ordering information

Part No.	Connector	Description
IWP048	2 way minitimer	5 hole cone spray fuel injector – Red band

For further details please contact

Competition Systems Ltd
 Hyjuniper, Long Lane
 Shaw, Berkshire,
 RG14 2TA
 England

Tel: +44 (0)8707 444666
 Fax: +44 (0)8707 444888
 mail@competitionsystems.co.uk
 www.competitionsystems.co.uk

IWP043 Fuel injector

4 hole – Cone spray, fuel injector



Description

This IWP043 "Pico" top feed injector is a production component with a multi hole 'cone' spray pattern and a wide range of applications for engines typically up to 50bhp per cylinder (depending on injection pressure)

The characteristics of the injector are a fast pulse response, high precision, high dynamic range and optimum fuel atomisation. These are achieved by a high performance ON-OFF actuating electromagnet with opposing expansion poles that moves an internal injector valve on high-precision ground cylindrical slides, and a high precision nozzle.

The injector has a stainless steel body, a fuel-resistant plastic connector, martensitic stainless steel internal valve and an electromagnet with a low carbon content stainless steel armature.

The electrical connection to the control unit is via a Mini-Timer plastic plug.



Technical Data

Performance - Typical

Flow Fully open
At 3 bar 329 cc/min – 3.75g/s
At 4 bar 377 cc/min – 4.30g/s
At 5 bar 421 cc/min – 4.80g/s
Cone – Inclusive 80% 20° Typ
Linearity range (at = 4 ms pulse) ± 3 %
Max. fuel pressure 500 kPa
Maximum duty cycle 90 %
Operating temperature range -30...110 °C
Vibration (peak) 30 g

Test conditions

Fluid N-Heptane
density (@ 20°C) 0.684 kg/litre

Ambient and fluid temperature 23 °C
Power supply 14 Vdc

Mechanical Characteristics

Height 47.2 mm
Outside diameter (connector excluded) 15.3 mm
Weight 35 g

Electrical Characteristics

Connector Mini-Timer 2 way
Power supply 8 ÷ 16 Vdc
Resistance 14.5 Ω
Driver type ON-OFF

PIN	Description
1	GND
2	+12 V

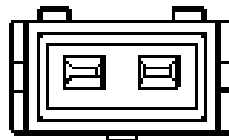

1 2

Electrical connections

Ordering information

Part No.	Connector	Description
IWP043	2 way minitimer	4 hole fuel injector – Brown band

Competition Systems Ltd Hyjuniper, Long Lane Shaw, Berkshire, RG14 2TA England	For further details please contact	Tel: +44 (0)8707 444666 Fax: +44 (0)8707 444888 mail@competitionsystems.co.uk www.competitionsystems.co.uk
--	------------------------------------	---

IWP189 Fuel injector

12 hole – Cone spray, shower injector



Description

This IWP189 "Pico" top feed injector is a production component with a multi hole 'cone' spray pattern and very high flow for use as a 'shower' injector directly downwards into the air intake of high performance engines.

The characteristics of the injector are a fast pulse response, high precision, high dynamic range and optimum fuel atomisation. These are achieved by a high performance ON-OFF actuating electromagnet with opposing expansion poles that moves an internal injector valve on high-precision ground cylindrical slides, and a high precision nozzle.



The injector has a stainless steel body, a fuel-resistant plastic connector, martensitic stainless steel internal valve and an electromagnet with a low carbon content stainless steel armature.

The electrical connection to the control unit is via a Mini-Timer plastic plug.



Technical Data

Performance - Typical

Flow..... 510 cc/min - 5.8g/s +/- 4%
Cone – Inclusive 80% 50° Typ
Linearity range (Tj = 4 ms) ± 4 %
Max. fuel pressure 500 kPa
Maximum duty cycle 90 %
Operating temperature range..... -30...110 °C
Vibration (peak) 30 g

Test conditions – cont'd

Injection frequency Fully open
Pressure..... 3 bar

Mechanical Characteristics

Height..... 47.2 mm
Outside diameter (connector excluded) 15.3 mm
Weight..... 35 g

Test conditions

Fluid..... N-Heptane
density (@ 20°C) 0.684 kg/litre
Ambient and fluid temperature 23 °C
Power supply 14 Vdc

Electrical Characteristics

Connector..... Mini-Timer 2 way
Power supply..... 8 ÷ 16 Vdc
Resistance 14.5 Ω
Driver type..... ON-OFF

PIN	Description
1	GND
2	+12 V

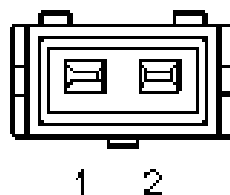

Electrical connections

Ordering information

Part No.	Connector	Description	Order Code
IWP189	2 way minitimer	High flow shower injector – multi hole	Use Part No.

Competition Systems Ltd Hyjuniper, Long Lane Shaw, Berkshire, RG14 2TA England	For further details please contact	Tel: +44 (0)8707 444666 Fax: +44 (0)8707 444888 mail@competitionsystems.co.uk www.competitionsystems.co.uk
--	------------------------------------	---

IWP162 Fuel injector

5 hole – Cone spray, fuel injector



Description

This IWP162 "Pico" top feed injector is a production component with a multi hole 'cone' spray pattern and a wide range of applications for engines typically up to 55bhp per cylinder (depending on injection pressure)

The characteristics of the injector are a fast pulse response, high precision, high dynamic range and optimum fuel atomisation. These are achieved by a high performance ON-OFF actuating electromagnet with opposing expansion poles that moves an internal injector valve on high-precision ground cylindrical slides, and a high precision nozzle.

The injector has a stainless steel body, a fuel-resistant plastic connector, martensitic stainless steel internal valve and an electromagnet with a low carbon content stainless steel armature.

The electrical connection to the control unit is via a Mini-Timer plastic plug.



Technical Data

Performance - Typical

Flow..... Fully open
 At 3 bar377 cc/min – 4.30g/s Cone
 – Inclusive 70% 24 ° Linearity
 range (at = 4 ms pulse) ± 4 % Max. fuel
 pressure500 kPa Maximum
 duty cycle 90 % Operating
 temperature range..... -30...110 °C Vibration
 (peak) 30 g

Test conditions

Fluid..... N-Heptane
 density (@ 20°C)0.684 kg/litre
 Ambient and fluid temperature 23 °C

Power supply..... 14 Vdc

Mechanical Characteristics

Height..... 47.2 mm
 Outside diameter (connector excluded) 15.3 mm
 Weight..... 35 g

Electrical Characteristics

Connector..... Mini-Timer 2 way
 Power supply..... 8 ÷ 16 Vdc
 Resistance 14.5 Ω
 Driver type..... ON-OFF

Electrical connections

PIN	Description
1	GND
2	+12 V

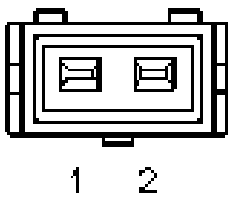

Spray Data

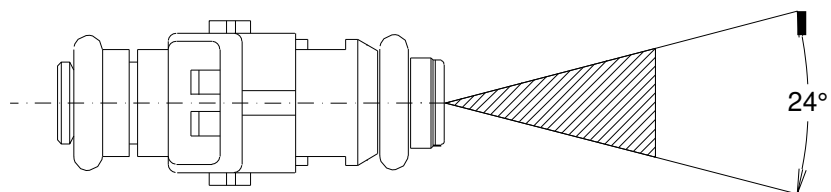

Ordering information

Part No.	Connector	Description
IWP162	2 way minitimer	5 hole cone spray fuel injector – White band

Competition Systems Ltd Hyjuniper, Long Lane Shaw, Berkshire, RG14 2TA England	For further details please contact	Tel: +44 (0)8707 444666 Fax: +44 (0)8707 444888 mail@competitionsystems.co.uk www.competitionsystems.co.uk
--	------------------------------------	---

IWP023 Fuel injector

Single hole – Cone spray, fuel injector



Description

This IWP023 "Pico" top feed injector is a production component with a single hole 'cone' spray pattern and a wide range of applications for engines typically for small engines up to 25bhp per cylinder (depending on injection pressure)

The characteristics of the injector are a fast pulse response, high precision, high dynamic range and optimum fuel atomisation. These are achieved by a high performance ON-OFF actuating electromagnet with opposing expansion poles that moves an internal injector valve on high-precision ground cylindrical slides, and a high precision nozzle.

The injector has a stainless steel body, a fuel-resistant plastic connector, martensitic stainless steel internal valve and an electromagnet with a low carbon content stainless steel armature.

The electrical connection to the control unit is via a Mini-Timer plastic plug.



Technical Data

Performance - Typical

Flow..... Fully open
 At 3 bar 158 cc/min – 1.8g/s
 Cone – Inclusive 80% 15° Typ
 Linearity range (at = 4 ms pulse) ± 4 %
 Max. fuel pressure 500 kPa
 Maximum duty cycle 90 %
 Operating temperature range -30...110 °C
 Vibration (peak) 30 g

Test conditions

Fluid..... N-Heptane
 density (@ 20°C) 0.684 kg/litre
 Ambient and fluid temperature 23 °C

Power supply..... 14 Vdc

Mechanical Characteristics

Height..... 47.2 mm
 Outside diameter (connector excluded) 15.3 mm
 Weight..... 35 g

Electrical Characteristics

Connector..... Mini-Timer 2 way
 Power supply..... 8 ÷ 16 Vdc
 Resistance 14.5 Ω
 Driver type..... ON-OFF

Electrical connections

PIN	Description
1	GND
2	+12 V

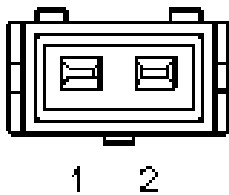

Spray Data

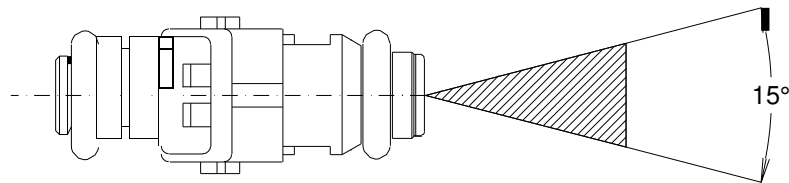

Ordering information

Part No.	Connector	Description
IWP023	2 way minitimer	Single hole fuel injector – Red band

Competition Systems Ltd Hyjuniper, Long Lane Shaw, Berkshire, RG14 2TA England	For further details please contact	Tel: +44 (0)8707 444666 Fax: +44 (0)8707 444888 mail@competitionsystems.co.uk www.competitionsystems.co.uk
--	------------------------------------	---

IWP069 Fuel injector

Single hole – Cone spray, fuel injector



Description

This IWP069 "Pico" top feed injector is a production component with a single hole 'cone' spray pattern and a wide range of applications for engines typically up to 85bhp per cylinder (depending on injection pressure)

The characteristics of the injector are a fast pulse response, high precision, high dynamic range and optimum fuel atomisation. These are achieved by a high performance ON-OFF actuating electromagnet with opposing expansion poles that moves an internal injector valve on high-precision ground cylindrical slides, and a high precision nozzle.

The injector has a stainless steel body, a fuel-resistant plastic connector, martensitic stainless steel internal valve and an electromagnet with a low carbon content stainless steel armature.

The electrical connection to the control unit is via a Mini-Timer plastic plug.



Technical Data

Performance - Typical

Flow Fully open

At 3 bar 491 cc/min – 5.60g/s

At 4 bar 563 cc/min – 6.42g/s

At 5 bar 629 cc/min – 7.17g/s

Cone – Inclusive 80% 15° Typ

Linearity range (at = 4 ms pulse) ± 4 %

Max. fuel pressure 500 kPa

Maximum duty cycle 90 %

Operating temperature range -30...110 °C

Vibration (peak) 30 g

Test conditions

Fluid N-Heptane

density (@ 20°C) 0.684 kg/litre

Ambient and fluid temperature 23 °C

Power supply 14 Vdc

Mechanical Characteristics

Height 47.2 mm

Outside diameter (connector excluded) 15.3 mm

Weight 35 g

Electrical Characteristics

Connector Mini-Timer 2 way

Power supply 8 ÷ 16 Vdc

Resistance 14.5 Ω

Driver type ON-OFF

PIN	Description
1	GND
2	+12 V

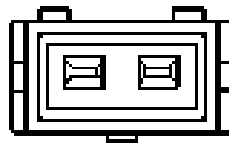

1 2

Electrical connections

Ordering information

Part No.	Connector	Description
IWP069	2 way minitimer	Single hole fuel injector – Yellow band

Competition Systems Ltd Hyjuniper, Long Lane Shaw, Berkshire, RG14 2TA England	For further details please contact	Tel: +44 (0)8707 444666 Fax: +44 (0)8707 444888 mail@competitionsystems.co.uk www.competitionsystems.co.uk
--	------------------------------------	---

IWP006 Fuel injector

4 hole - Twin spray, fuel injector



Description

This IWP006 "Pico" top feed injector is a production component with a multi hole 'twin stream' spray pattern and a wide range of applications for engines typically up to 35bhp per cylinder (depending on injection pressure), on engines with a 4 valve head and the injector positioned close to the valve.

The characteristics of the injector are a fast pulse response, high precision, high dynamic range and optimum fuel atomisation. These are achieved by a high performance ON-OFF actuating electromagnet with opposing expansion poles that moves an internal injector valve on high-precision ground cylindrical slides, and a high precision nozzle.

The injector has a stainless steel body, a fuel-resistant plastic connector, martensitic stainless steel internal valve and an electromagnet with a low carbon content stainless steel armature.

The electrical connection to the control unit is via a Mini-Timer plastic plug.



Technical Data

Performance - Typical

Flow..... Fully open
At 3 bar 226 cc/min – 2.58g/s
Cone – Inclusive 80% See Drawing
Linearity range (at = 4 ms pulse) ± 4 %
Max. fuel pressure 500 kPa
Maximum duty cycle 90 %
Operating temperature range..... -30...110 °C
Vibration (peak) 30 g

Test conditions

Fluid..... N-Heptane
density (@ 20°C) 0.684 kg/litre
Ambient and fluid temperature 23 °C

Power supply..... 14 Vdc

Mechanical Characteristics

Height..... 47.2 mm
Outside diameter (connector excluded) 15.3 mm
Weight..... 35 g

Electrical Characteristics

Connector..... Mini-Timer 2 way
Power supply..... 8 ÷ 16 Vdc
Resistance 14.5 Ω
Driver type..... ON-OFF

Electrical connections

PIN	Description
1	GND
2	+12 V

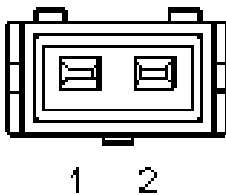

Spray data

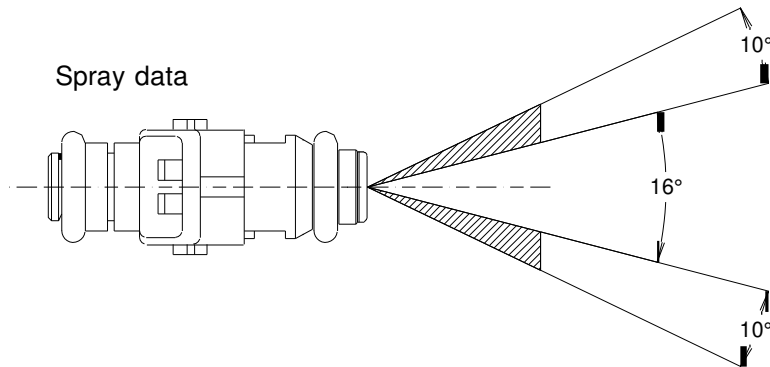

Ordering information

Part No.	Connector	Description
IWP006	2 way minitimer	4 hole fuel injector / Split stream – Blue band

Competition Systems Ltd Hyjuniper, Long Lane Shaw, Berkshire, RG14 2TA England	For further details please contact	Tel: +44 (0)8707 444666 Fax: +44 (0)8707 444888 mail@competitionsystems.co.uk www.competitionsystems.co.uk
--	------------------------------------	---

Pico fuel injectors

Spray patterns



The following spray pattern information is applicable to all of the 'Pico' style fuel injectors.

All data is nominal and cannot be guaranteed – For users with very specific requirements we suggest that you make selective testing.

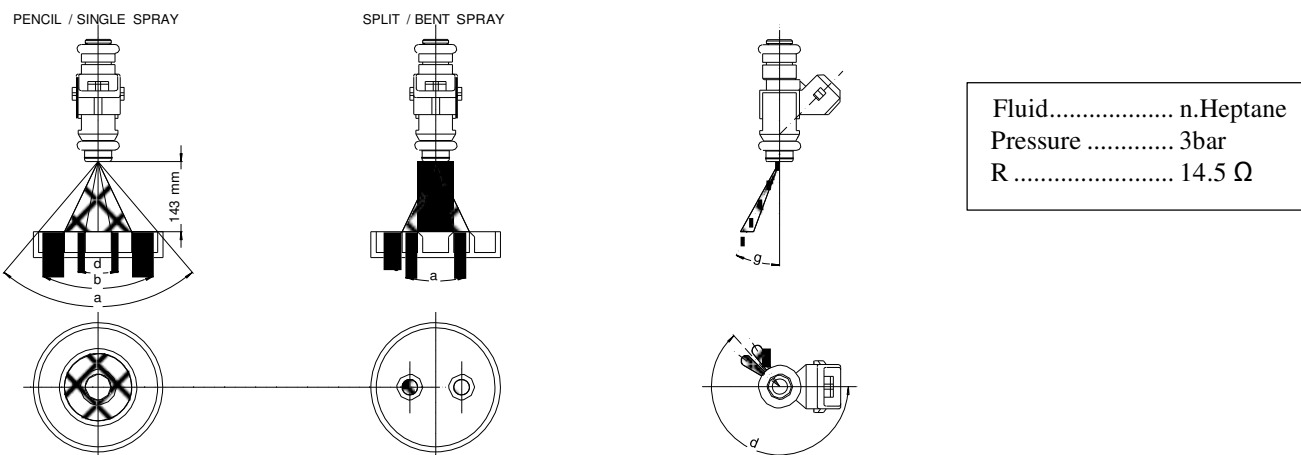

Fluid..... n.Heptane
 Pressure 3bar
 R 14.5 Ω

CODE	STATIC FLOW (cc/min)	CONNECTOR ANGLE	SPRAY CONFIGURATION	a	b	g	d
IWP 001	200	60°	BENT STREAM	16°	10°	25°	90°
IWP 006	226	45°	SPLIT STREAM	16°	10°	0°	0°
IWP 023	158	45°	SINGLE STREAM	---	15°	---	---
IWP 025	200	45°	SPLIT STREAM	18°	10°	0°	180°
IWP 042	N/a	45°	SPLIT STREAM	19°	10°	0°	230°
IWP 043	329	45°	SINGLE STREAM	---	20°	---	---
IWP 045	200	45°	BENT STREAM	16°	10°	25°	45°
IWP 048	215	60°	SINGLE STREAM	---	24°	---	---
IWP 049	184	45°	SINGLE STREAM	---	15°	---	---
IWP 058	Information not available						
IWP 064	186	60°	BENT STREAM	14°	12°	20°	90°
IWP 065	158	60°	SINGLE STREAM	---	15°	---	---
IWP 069	491	60°	SINGLE STREAM	---	15°	---	---
IWP 076	215	60°	SINGLE STREAM	---	24°	---	---
IWP 092	Information not available						
IWP 109	Information not available						
IWP 119	Information not available						
IWP 116	Information not available						
IWP 162	377	60°	SINGLE STREAM	---	24°	---	---
IWP 164	Information not available						
IWP 189	490	60°	SINGLE STREAM	---	24°	---	---

For further details please contact

Competition Systems Ltd
 Hyjunction, Long lane, Shaw
 Newbury, Berkshire,
 RG14 2TA
 England

Tel: +44 (0)8707 444666
 Fax: +44 (0)8707 444888
www.competitionssystem.co.uk
mail@competitionssystem.co.uk