

S-CAN 3D Ltd.

Unit 10b
Bunn's Bank Ind Est,
Attleborough
Norfolk
UK
NR17 1QD

Tel +44 (0)1953 857800
Email info@atpowerthrottles.com
Web www.atpower.com



Porsche Throttle Terminology

DATASHEET REV001 11.25

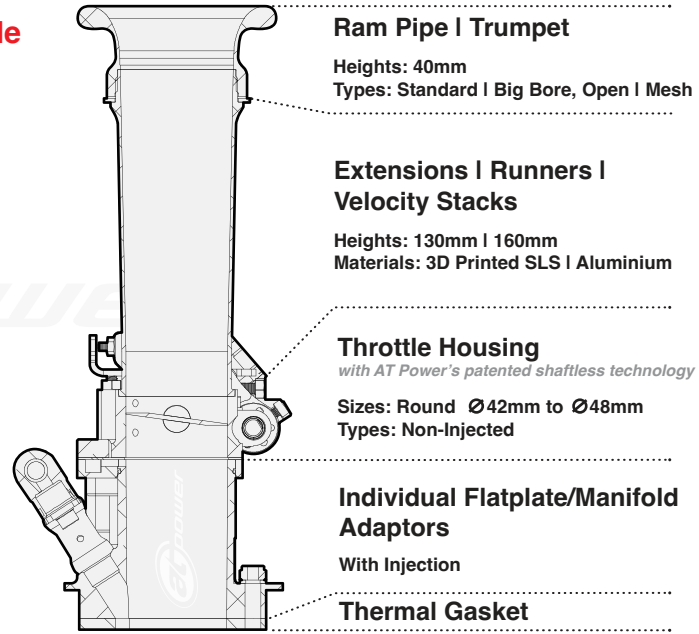
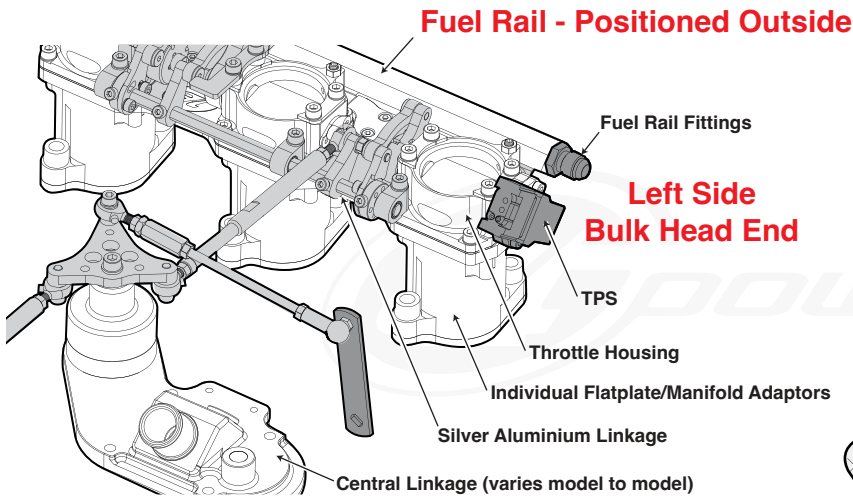

Types - Aluminium pieces can be anodised

Standard configurations use the maximum intake length to deliver peak torque. Achieving maximum torque requires a long intake with a tapered bore. These are the Extension and Ram Pipes available. For something different please contact us.

	Standard Setup	Large Bore	Electric Spoiler
Ram Pipes	<p>Aluminium</p> <p>40mm Mesh For aluminium extensions</p> <p>40mm Open For aluminium extensions</p>	<p>40mm Open Big Bore For aluminium extensions</p> <p>40mm Mesh Big Bore For aluminium extensions</p>	<p>40mm Mesh For 3D printed extensions</p> <p>40mm Open For 3D SLS extensions</p>
Extensions Types	<p>Standard Aluminium Extensions 130mm 160mm</p>	<p>Large Bore Aluminium Extensions 130mm 160mm</p>	<p>Curved 160mm Black laser sintered PA12 Nylon 3D printed extension for electric spoiler</p> <p>GT3 Plenum Adaptor NA & Turbo Setup (No Trumpet required)</p>

You can order additional sets of extensions and trumpets to make your setup more versatile, especially if you have multifunctional needs. For a personal touch, consider choosing extra sets in a range of aluminium anodised colour finishes.

S-CAN 3D Ltd.

Unit 10b
Bunn's Bank Ind Est,
Attleborough
Norfolk
UK
NR17 1QD

Tel +44 (0)1953 857800
Email info@atpowerthrottles.com
Web www.atpower.com



Drive by Wire Throttle Actuator

Drive by Wire Electronic Throttle Actuator

A drive by wire electronic throttle actuator is possible to install on each bank of throttles or a single DBW centrally mounted. Contact us for this setup.

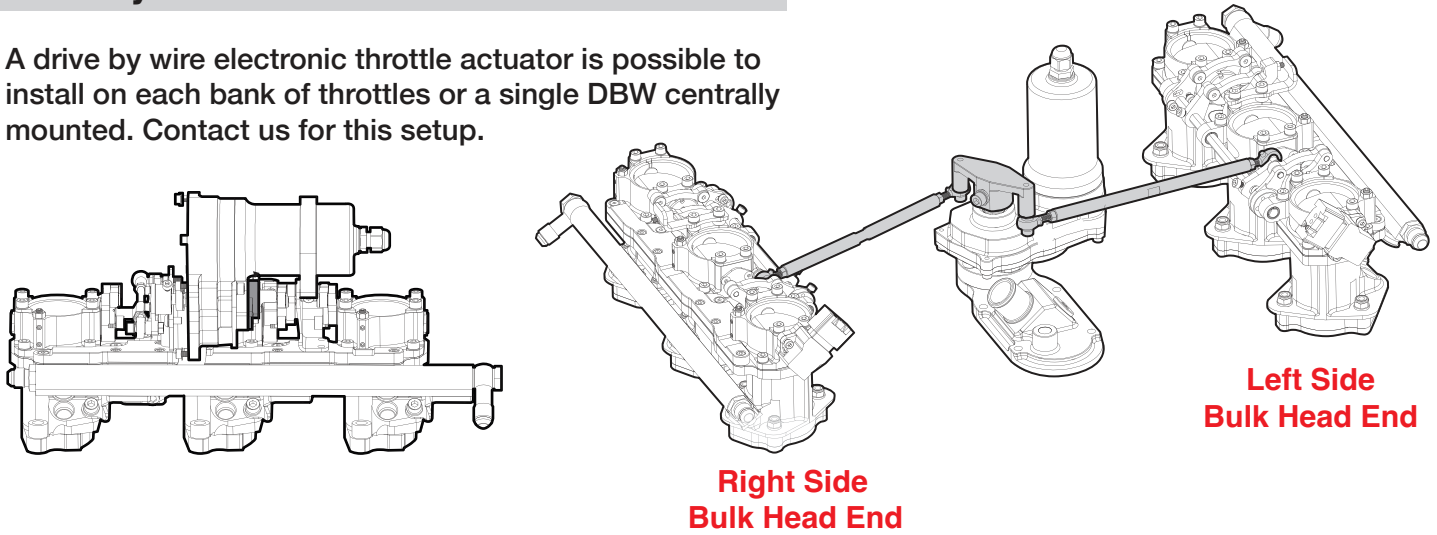

Fuel Rails and Fittings

If you need to change AT Power's fuel rail fittings, contact us with your serial number and we will advise accordingly. Do **not** remove the end fittings yourself, as this will cause damage and will void your warranty.

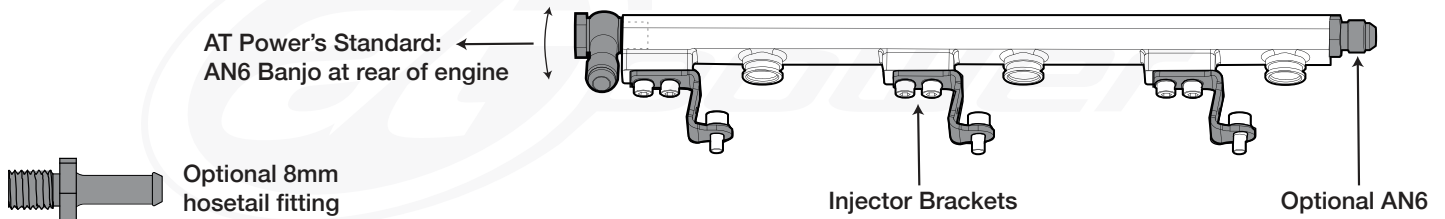

Injector Brackets - Standard Options

Unless specified you will get pico brackets as standard, however, these are the other brackets we offer:

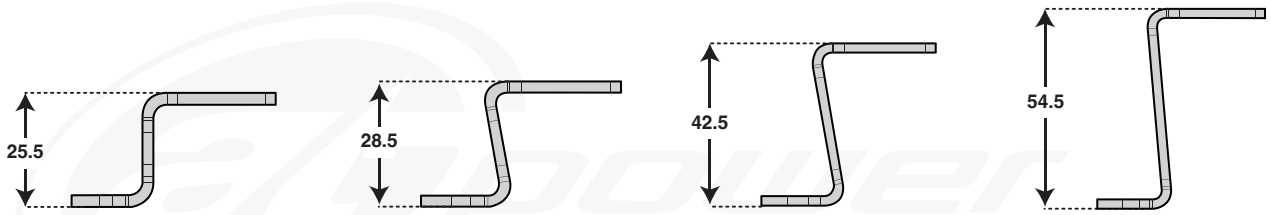

Suits	Bosch EV14 Short
Part	102-211-00204

Suits	Pico's
Part	102-211-00064

Suits	Bosch EV14 Standard & EV12 Injectors
Part	102-211-00286

Suits	Bosch EV14 Long & EV6 Injectors
Part	102-211-00287

S-CAN 3D Ltd.

Unit 10b
Bunn's Bank Ind Est,
Attleborough
Norfolk

NR17 1QD

Tel +44 (0)1953 857800
Email info@atpowerthrottles.com
Web www.atpower.com



**Porsche 911 & 964
Brake Boost & Cold Idle Control**

SKU 102-134-00018
DATASHEET REV002 27.2.25

Brake boost is required for hydraulic assisted brakes. IAC is required for cold idle control for use with Emerald ECU kits.

Assembly comes with all components to provide 3 setup options:

1. Brake boost only

Brake boost for hydraulic-assisted brakes.

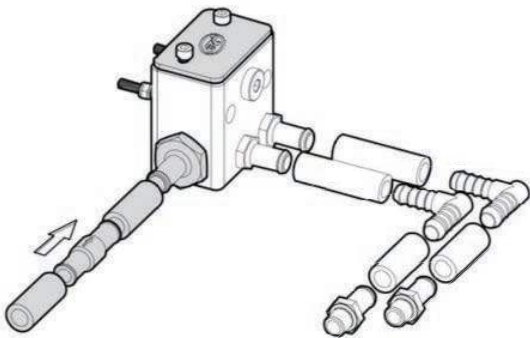

2. Idle air control (IAC) only

IAC is required for cold idle management with certain ECU kits.

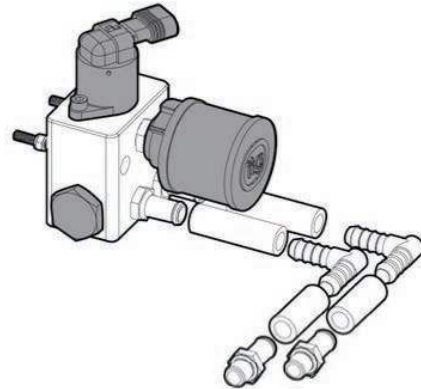

IAC Valve Pin Out

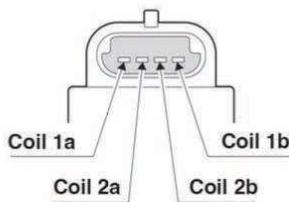

3. IAC and brake boost

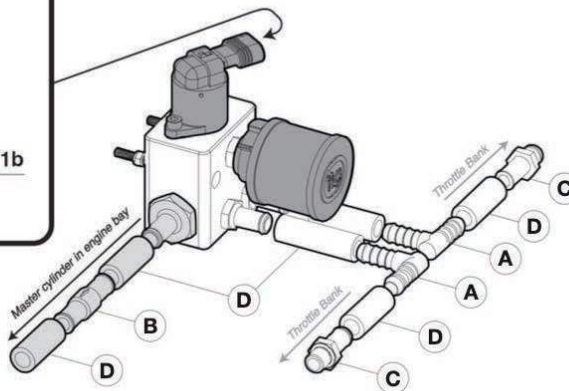

- A. 90° Elbow
- B. Non Return Valve
- C. Hose Tale Fitting
- D. 3m Silicon Hose (Cut to Length)

S-CAN 3D Ltd.

Unit 10b
Bunn's Bank Ind Est,
Attleborough
Norfolk

NR17 1QD

Tel +44 (0)1953 857800
Email info@atpowerthrottles.com
Web www.atpower.com



Optional Harness and ECU

What's included:

Details may vary depending on year and model setup.

911 (1969-1977) Kit Includes

- Cylinder heat temperature sensor & mount
- Emerald K6 ECU & Base map
- Emerald wiring loom
- Emerald wide band lambda kit
- 6 cylinder coil pack
- Set of HT leads
- Trigger wheel
- Trigger wheel sensor
- Distributor cover



911 (1979-1989) Kit Includes

- Emerald K6 ECU & Base map
- Emerald wiring loom
- Emerald wide band lambda kit
- 4 Wire extension for IAC or DBW control
- Air temp sensor



964 | 993 Kit Includes

- Emerald K6 ECU & Base map
- Emerald wiring loom
- Emerald wide band lambda kit
- 4 Wire extension for IAC or DBW control
- Air temp sensor

S-CAN 3D Ltd.

Unit 10b
Bunn's Bank Ind Est,
Attleborough
Norfolk

NR17 1QD

Tel +44 (0)1953 857800
Email info@atpowerthrottles.com
Web www.atpower.com



Optional Fuel System, Heater Duct & Engine Breather REV001 16.3.26

What's included:

911 (1969-1977) & SC Kit Includes

- Fuel pressure regulator/gauge
- 8 x AN6 Straight hose
- 5 x M14 x 1.5 male to male
- 6 x 90° AN6 Hose
- 'Y' Piece Adaptor
- 6 x IWP162 Pico 377c Injectors
- Nylon braided hose



911 (1979-1989) Kit Includes

- Fuel pressure regulator/gauge
- 5 x AN6 Straight hose
- 1 x M14 x 1.5 male to male
- 3 x M14 to JIC-6 male to male
- 5 x 90° AN6 Hose
- 'Y' Piece Adaptor
- 6 x IWP162 Pico 377c Injectors
- Nylon braided hose



964 | 993 Kit Includes

- Fuel pressure regulator/gauge
- 8 x AN6 Straight hose
- 5 x M14 to JIC male to male
- 6 x 90° AN6 Hose
- 'Y' Piece Adaptor
- 6 x IWP162 Pico 377c Injectors
- Nylon braided hose



S-CAN 3D Ltd.

Unit 10b
Bunn's Bank Ind Est,
Attleborough
Norfolk

NR17 1QD

Tel +44 (0)1953 857800
Email info@atpowerthrottles.com
Web www.atpower.com



Supporting Throttle Products

AT Power offers a range of supporting products to assist with your throttle installation.

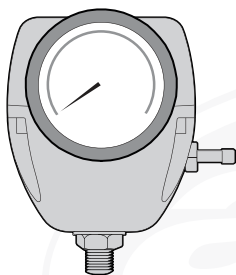
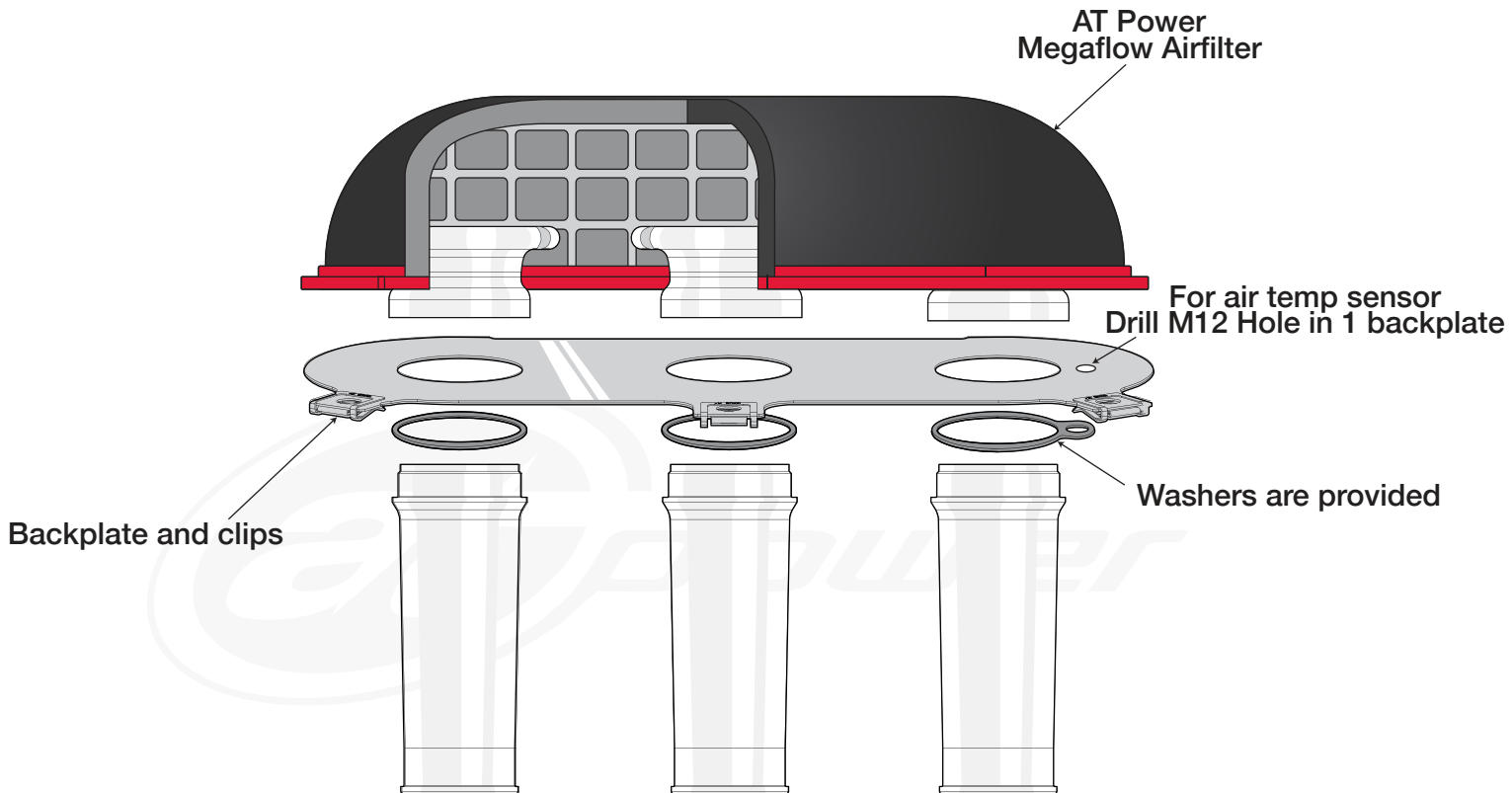

Fuel Pressure
Regulator

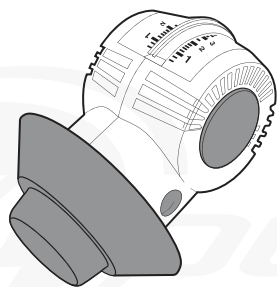

Airflow Synchrometer
Used for balancing

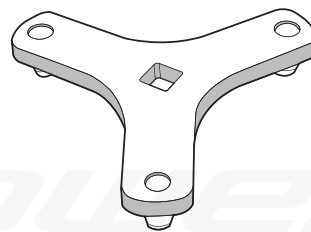

Ram Pipe
Torque Tool



IAC Valve

3m Motorsport
Throttle Cable

Pico Fuel
Injectors

