

RIGHT SIDE

LEFT SIDE

CENTRAL CABLE PULL WITH IDLE ADJUSTMENT

FUEL RAIL TO UTILIZE INJECTOR POCKETS IN THE CYLINDER HEAD. AN-6 MALE FITTINGS AT BOTH ENDS

MEGAGLOW AIR FILTER SOLD SEPARATLY
JC50/S65
PART No. 102-108-00039

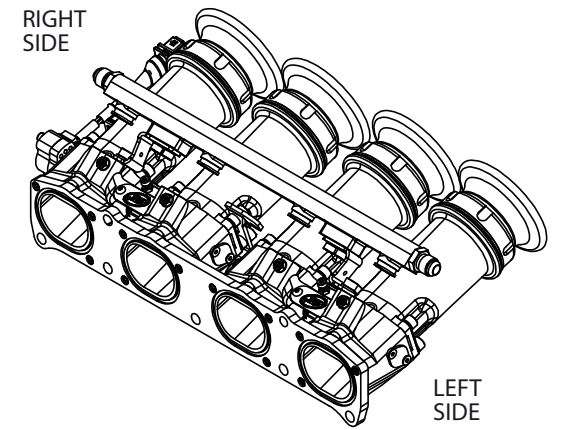

RIGHT SIDE

LEFT SIDE

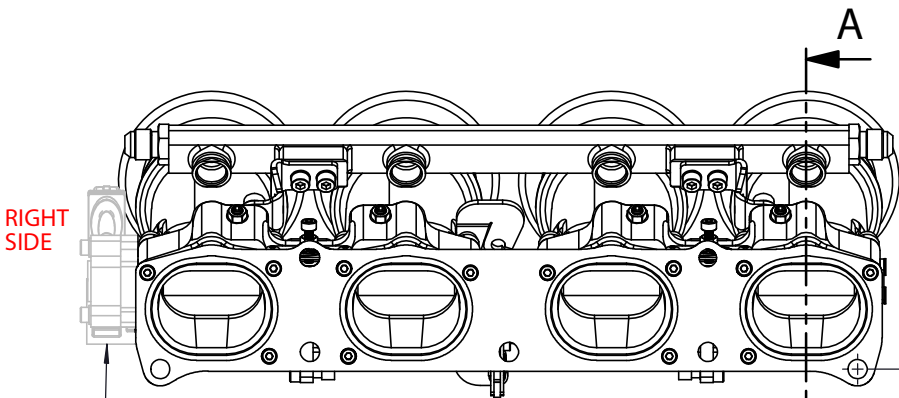

RIGHT SIDE

LEFT SIDE

WABASH PICTURED
TPS OPTIONS AVAILABLE
CAN BE FITED ON LEFT OR RIGHT SIDE

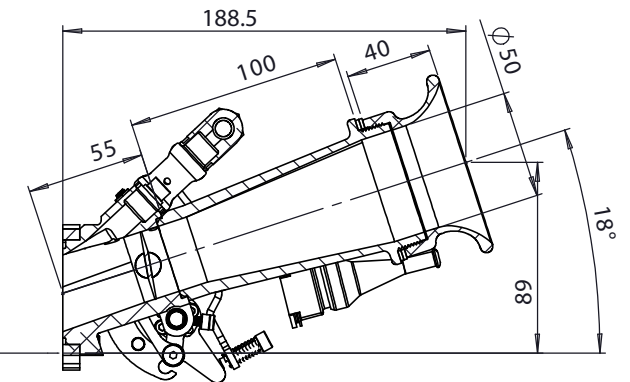

SECTION A-A

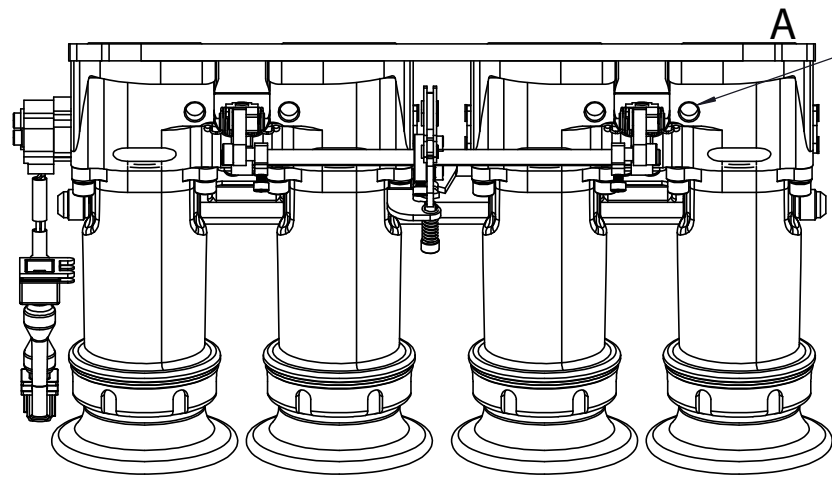

1/8" BSP VACUUM TAKE OFFS AVAILABLE
DRILL 4MM HOLES THROUGH IF REQUIRED



S-CAN 3D Ltd
Bunns Bank Ind Est
Attleborough NR17 1QD

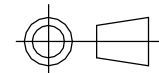

THIRD ANGLE PROJECTION

SCALE 1:2.5 WEIGHT 2746.714 kg

DRAWN - S.HOW

DATE - 15/09/25

CHECKED - S.HOW

APPROVED - S.HOW

UNLESS OTHERWISE STATED:
DIMENSIONS IN MILLIMETRES
TOLERANCES: LINEAR ±0.1 ANGULAR ±0.5°
SURFACE FINISH √ = √
DRAWING STANDARDS TO ATQS 6003
DATE FORMAT: DD/MM/YY

THIS DESIGN IS THE PROPERTY OF S-CAN 3D LTD AND MUST NOT BE REPRODUCED OR COMMUNICATED WITHOUT AUTHORITY

CAD PLOT DO NOT SCALE

MATERIAL	SEE COMPONENT PARTS
FINISH	SEE COMPONENT PARTS
DRAWING TITLE	ASSY - FORD - DURATEC - 2.0L & 2.3L - 42MM - INJECTED - PRE-CONFIGURED
DRAWING NUMBER	102-102-00605