

Select Left Hand Side TPS

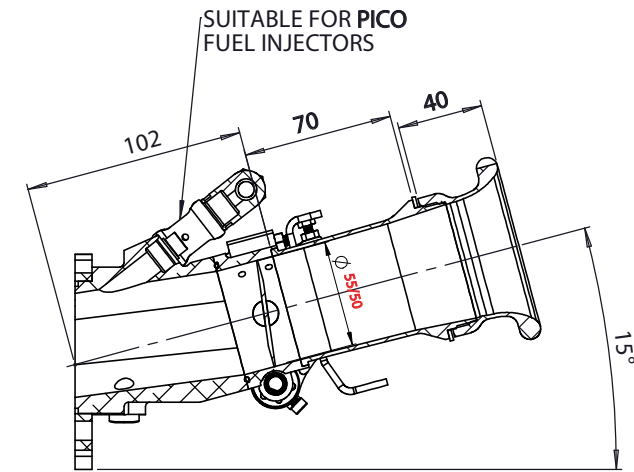

SECTION A-A

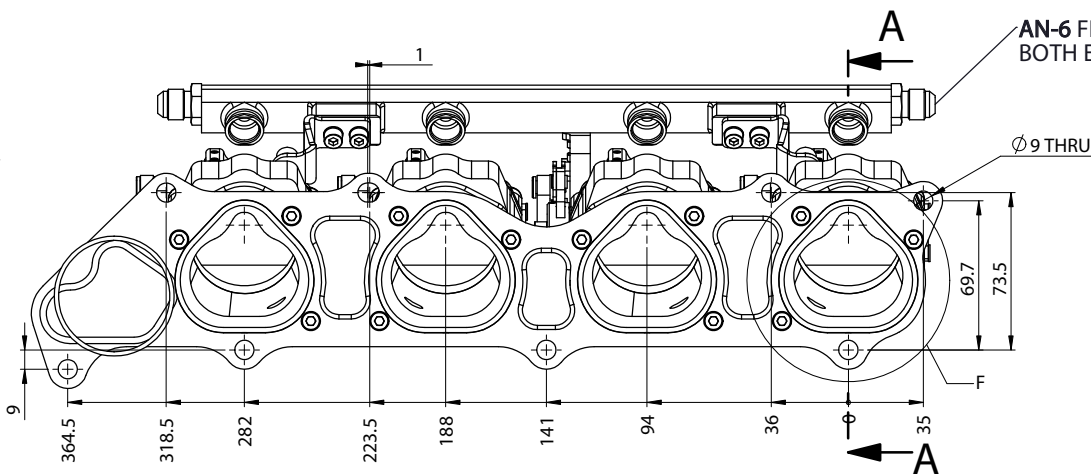
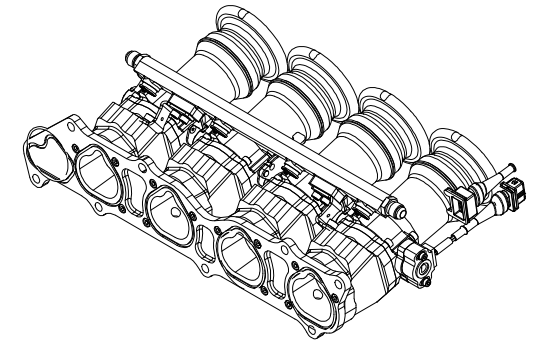
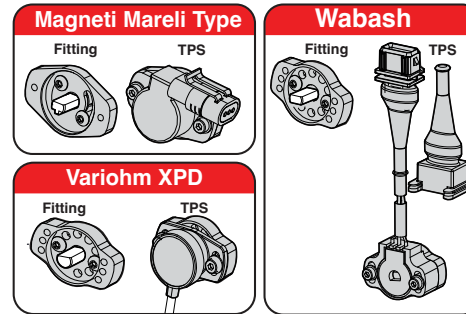

S-CAN 3D Ltd
Bunns Bank Ind Est
Attleborough NR17 1QD

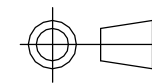

THIRD ANGLE PROJECTION

SCALE 1:2.5

WEIGHT 4360.186 kg

DRAWN- S.HOW

DATE- 21/07/25

CHECKED - S.HOW

APPROVED - S.HOW

UNLESS OTHERWISE STATED:
DIMENSIONS IN MILLIMETRES
TOLERANCES: LINEAR ±0.1 ANGULAR ±0.5°
SURFACE FINISH √ = √
DRAWING STANDARDS TO ATQS 6003
DATE FORMAT: DD/MM/YY

THIS DESIGN IS THE PROPERTY OF
S-CAN 3D LTD AND MUST NOT BE
REPRODUCED OR COMMUNICATED
WITHOUT AUTHORITY

CAD PLOT
DO NOT
SCALE

MATERIAL

SEE COMPONENT PARTS

FINISH

SEE COMPONENT PARTS

DRAWING TITLE

ASSY - HONDA - K20 - FD2 -
50/55MM- STD PORT - CABLE

DRAWING NUMBER

102-102-00593 = 50mm Throttle
102-102-00595 = 55mm Throttle