

CENTRE PULL CABLE LINKAGE AND IDLE ADJUSTMENT

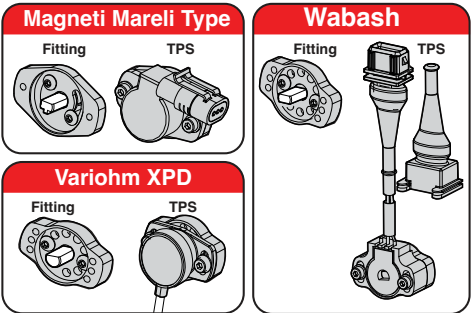

TPS OPTIONS AVAILABLE
CAN BE FITTED LEFT
OR RIGHT SIDE
(MAGNETI MARELI TYPE PICTURED)

MEGAFLOW AIR FILTER SOLD SEPARATELY
JC50/S65
PART No. 102-108-00039

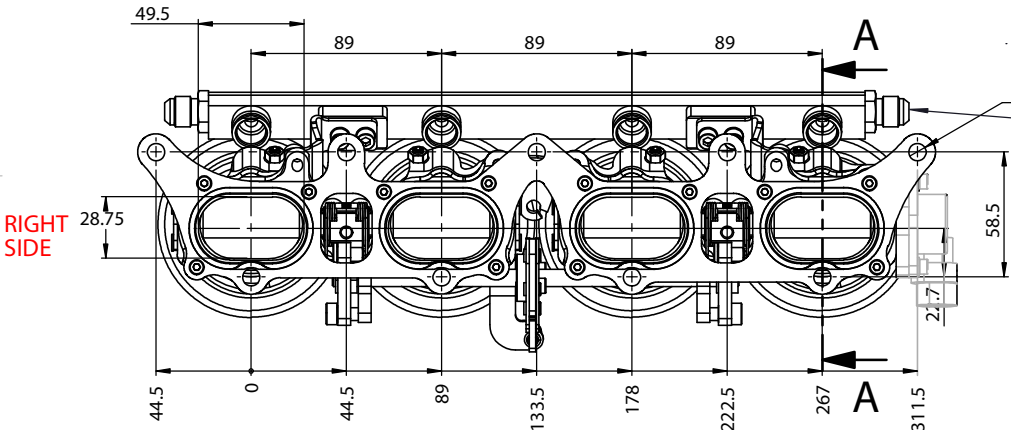
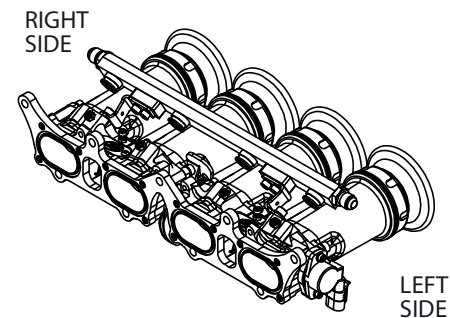

Ø 8.1 THRU
AN-6 MALE FITTINGS
BOTH ENDS
FUEL RAIL BRACKETS TO
SUITE PICO INJECTORS

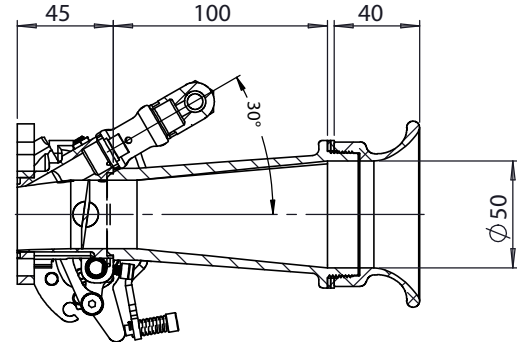

SECTION A-A

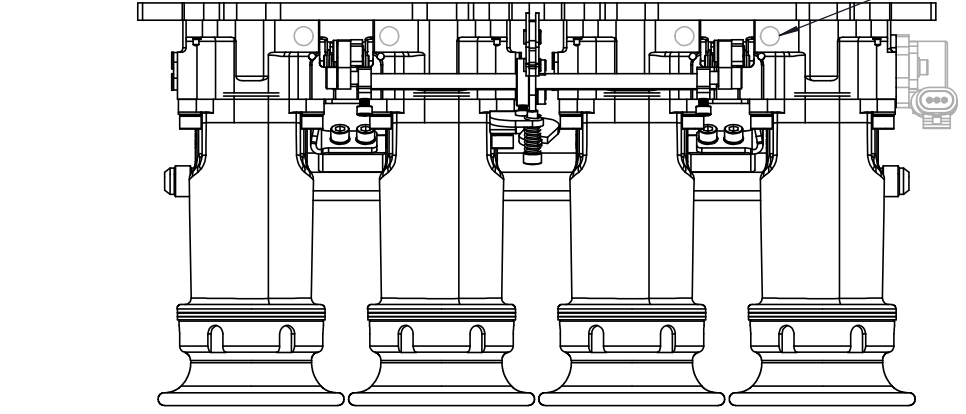

1/8" BSP VACUUM TAKE OFFS AVAILABLE
DRILL 4MM HOLE THROUGH IF REQUIRED

S-CAN 3D Ltd
Bunns Bank Ind Est
Attleborough NR17 1QD

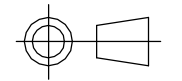

THIRD ANGLE PROJECTION
SCALE 1:2.5 WEIGHT 2.428 kg

UNLESS OTHERWISE STATED:
DIMENSIONS IN MILLIMETRES
TOLERANCES: LINEAR ±0.1 ANGULAR ±0.5°
SURFACE FINISH ✓ = ✓
DRAWING STANDARDS TO ATQS 6003
DATE FORMAT: DD/MM/YY
THIS DESIGN IS THE PROPERTY OF
S-CAN 3D LTD AND MUST NOT BE
REPRODUCED OR COMMUNICATED
WITHOUT AUTHORITY

CAD PLOT
DO NOT
SCALE

DRAWN- S.SHOW
DATE- 03/10/25
CHECKED- S.SHOW
APPROVED- S.SHOW

MATERIAL	SEE COMPONENT PARTS
FINISH	SEE COMPONENT PARTS
DRAWING TITLE	ASSY - RENAULT F4R 172/182 - 42MM - PRE-CONFIGURED
DRAWING NUMBER	102-102-00623