

M16 X 1.5 WATER OUTLET  
SUPPLIED WITH PLUG

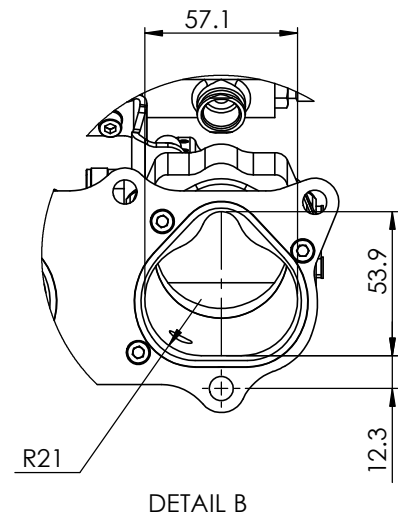
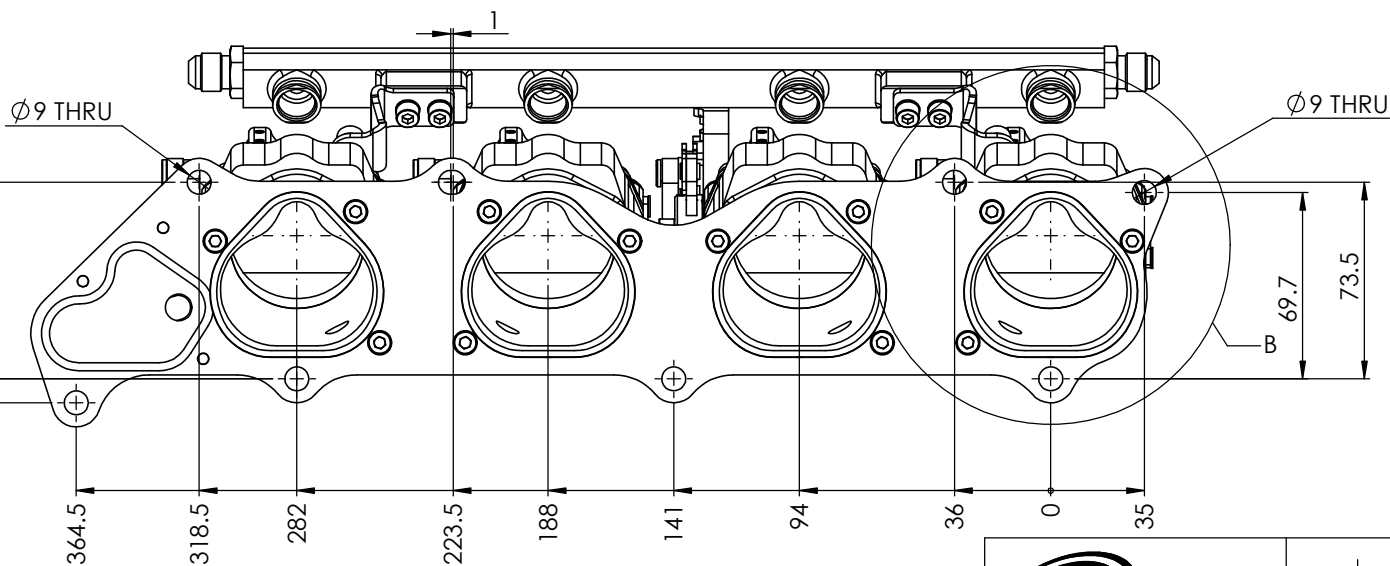
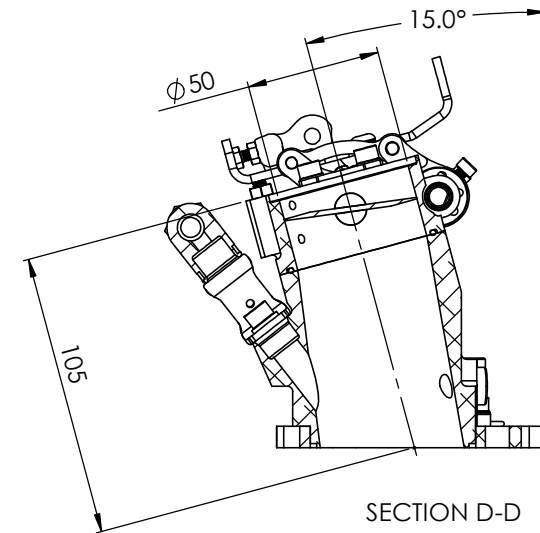
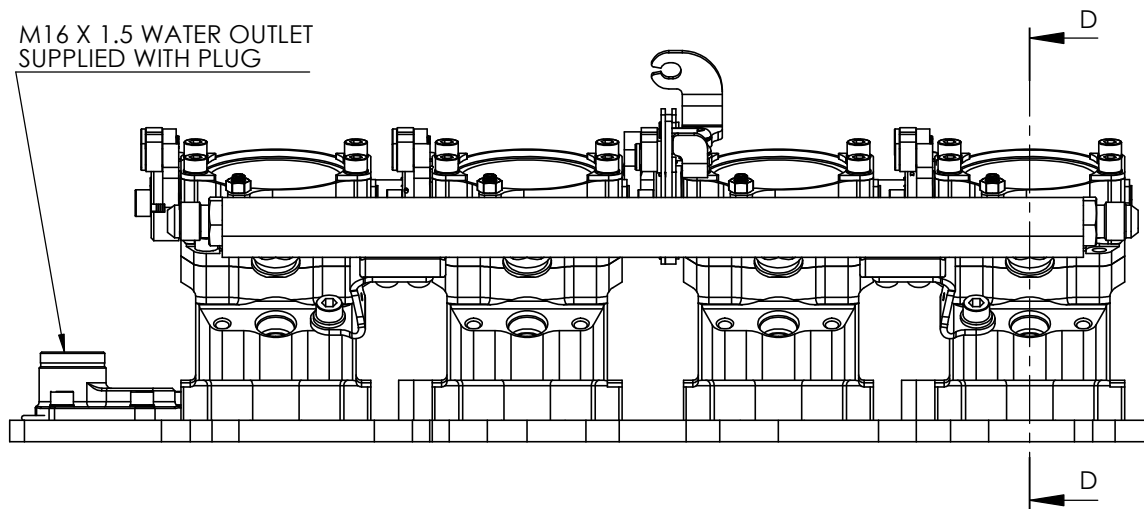

S-CAN 3D Ltd  
Bunns Bank Ind Est  
Attleborough NR17 1QD

UNLESS OTHERWISE STATED:  
DIMENSIONS IN MILLIMETRES  
TOLERANCES: LINEAR  $\pm 0.1$  ANGULAR  $\pm 0.5^\circ$   
SURFACE FINISH  $\sqrt{\text{V}}$  =  $\sqrt{\text{V}}$   
DRAWING STANDARDS TO ATQS 6003  
DATE FORMAT: DD/MM/YY

THIS DESIGN IS THE PROPERTY OF  
S-CAN 3D LTD AND MUST NOT BE  
REPRODUCED OR COMMUNICATED  
WITHOUT AUTHORITY

CAD PLOT  
DO NOT  
SCALE

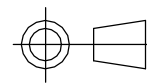

THIRD ANGLE PROJECTION

SCALE  
1:2

WEIGHT  
3.4 kg

DRAWN- S.HOW

DATE - 05/09/25

CHECKED - S.HOW

APPROVED - A.CLIFTON

MATERIAL

SEE COMPONENT PARTS

FINISH

SEE COMPONENT PARTS

DRAWING TITLE

ASSY - HOUSING - UNIVERSAL -  
HONDA - K20 - FD2 - 50MM -  
PORTED - ALI EXT - CABLE

DRAWING NUMBER

102-109-00038

SHEET 2 OF 2 A3