

USE STANDARD (OEM) INJECTORS AND FUEL RAIL NOT SUPPLIED

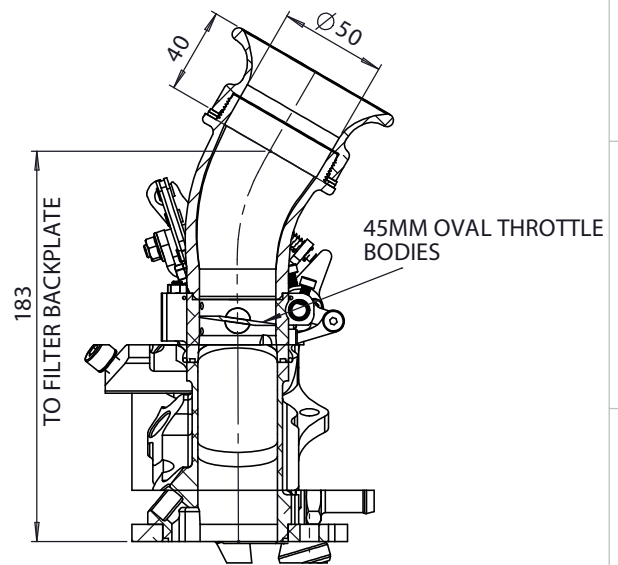

SECTION A-A

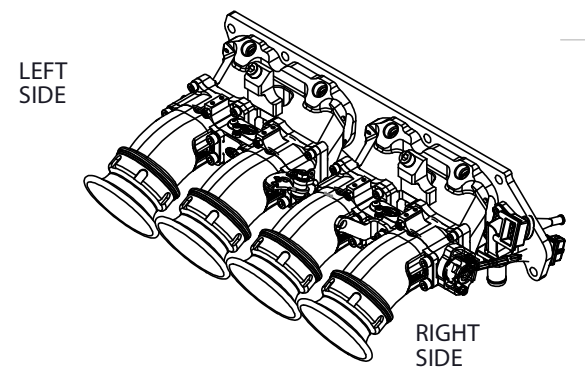

LEFT SIDE

RIGHT SIDE

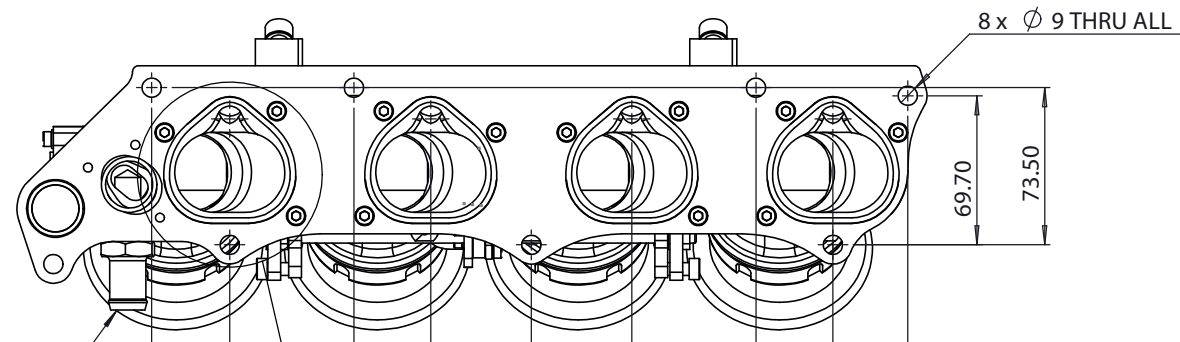

WATER OUTLET
17mm O/D
HOSE FITTING

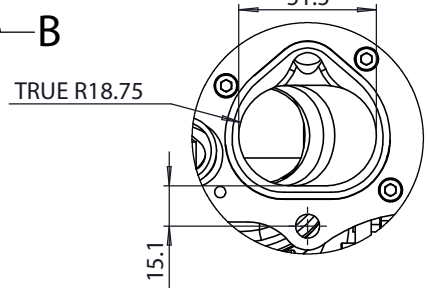

DETAIL B
SCALE 1 : 2

NOTE:
THIS PRODUCT REQUIRES AN
AFTERMARKET ENGINE MANAGEMENT
SYSTEM (ECU) FOR CORRECT ENGINE
FUELING OPERATION



S-CAN 3D Ltd
Bunns Bank Ind Est
Attleborough NR17 1QD

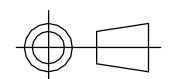

THIRD ANGLE PROJECTION
SCALE 1:2.5 WEIGHT 3.930 kg

DRAWN- S.HOW

DATE- 17/05/22

CHECKED - S.HOW

APPROVED - S.HOW

UNLESS OTHERWISE STATED:
DIMENSIONS IN MILLIMETRES
TOLERANCES: LINEAR ±0.1 ANGULAR ±0.5°
SURFACE FINISH √ = √
DRAWING STANDARDS TO ATQS 6003
DATE FORMAT: DD/MM/YY

THIS DESIGN IS THE PROPERTY OF
S-CAN 3D LTD AND MUST NOT BE
REPRODUCED OR COMMUNICATED
WITHOUT AUTHORITY

CAD PLOT
DO NOT
SCALE

MATERIAL	SEE COMPONENT PARTS
FINISH	SEE COMPONENT PARTS
DRAWING TITLE	ASSY-TWIN-HONDA-K20-FD2- STAGGERED-STANDARD INSTALLATION KIT-ITG FILTER
DRAWING NUMBER	102-102-00373