

Right Side

Left Side

Ensure sizes fit in engine

Available Trumpets:

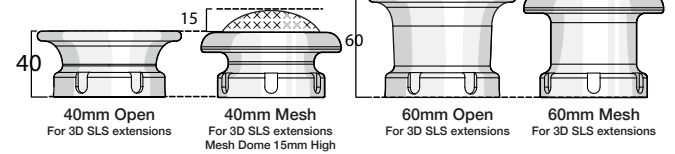

Available Extension Lengths: Contact us for curved

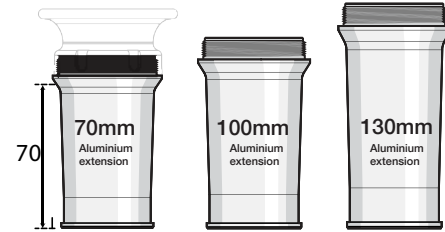

Available TPS Sides and TPS Options

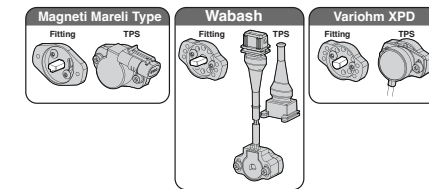

Available Fuel Injector Mounting Brackets:

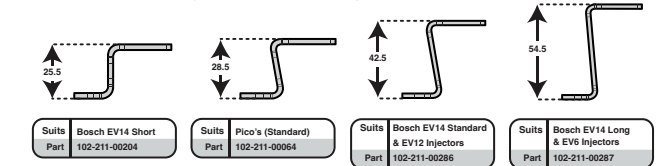

Available Fuel Rail End Fittings:

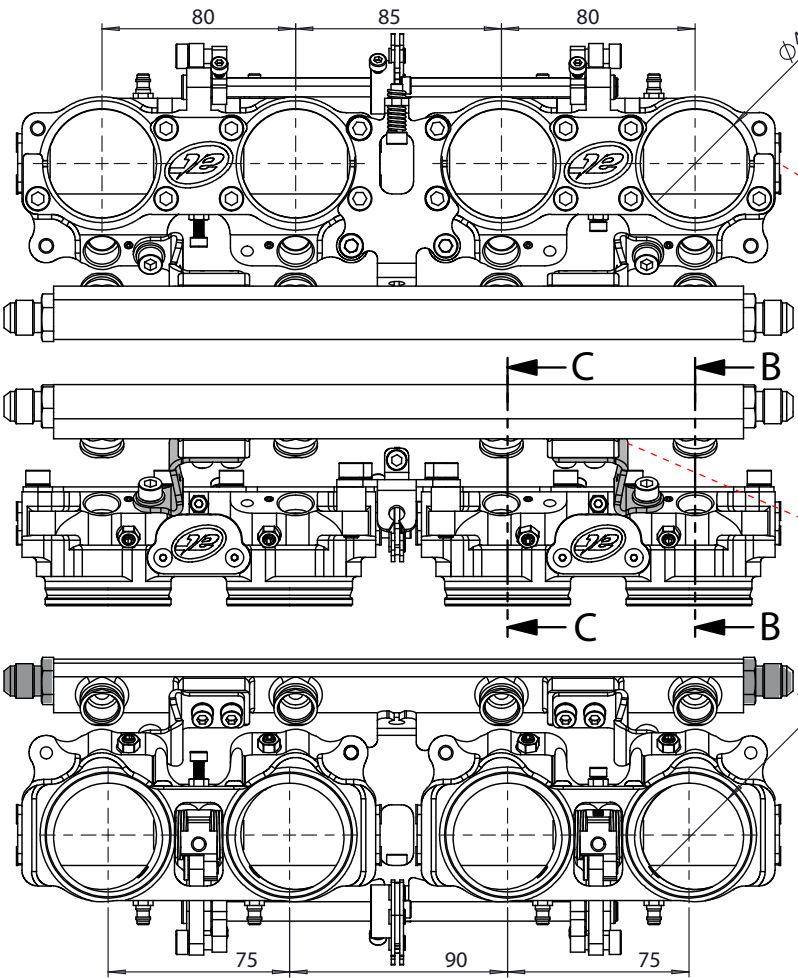

SECTION C-C

SCALE 1:2
THROUGH HEAD
INTERFACE BORE

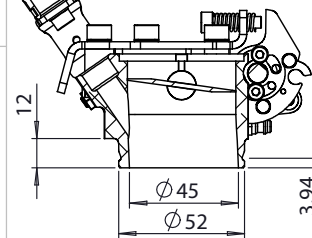

SECTION B-B

SCALE 1:2
THROUGH BLADE BORE

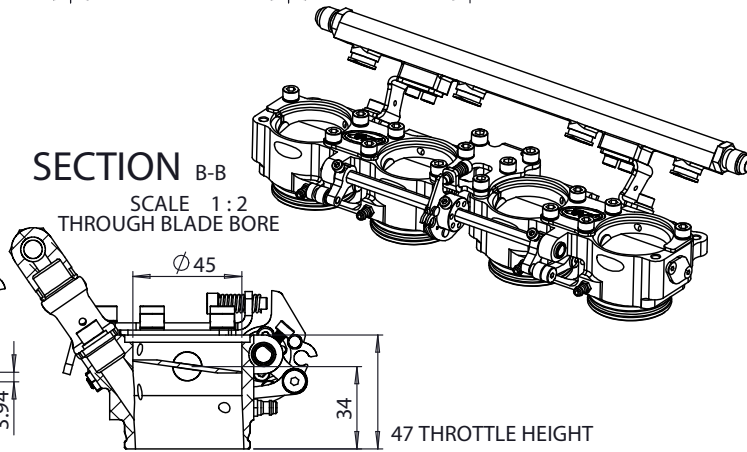

S-CAN 3D Ltd
Bunns Bank Ind Est
Attleborough NR17 1QD

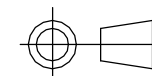

THIRD ANGLE PROJECTION

SCALE 1:1.5 WEIGHT 1.4 kg

DRAWN- S.HOW

DATE- 14/09/21

CHECKED- S.HOW

APPROVED- A.CLIFTON

UNLESS OTHERWISE STATED:
DIMENSIONS IN MILLIMETRES
TOLERANCES: LINEAR ±0.1 ANGULAR ±0.5°
SURFACE FINISH ✓ = ✓
DRAWING STANDARDS TO ATQS 6003
DATE FORMAT: DD/MM/YY
THIS DESIGN IS THE PROPERTY OF
S-CAN 3D LTD AND MUST NOT BE
REPRODUCED OR COMMUNICATED
WITHOUT AUTHORITY

CAD PLOT
DO NOT
SCALE

MATERIAL

SEE COMPONENT PARTS

FINISH

SEE COMPONENT PARTS

DRAWING TITLE

ASSY - HOUSING - TWIN -
HAYABUSA - SINGLE
INJECTED - GEN 2 - 45MM

DRAWING NUMBER

Select Cable Pull or Drive-By-Wire

Cable Pull Linkage

All Linkage suitable for AT Power's 3m Motorsport Throttle Nipple Cable (Sold Separately)

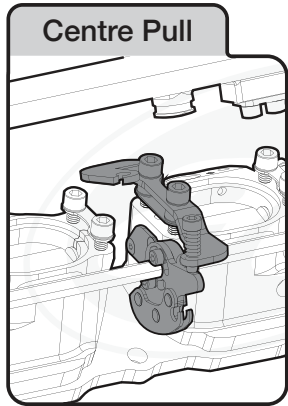

DBW (Drive-By-Wire) Actuator Mounting

If you have selected DBW an Optional XPK Variohm Hall Effect TPS is available.

Ensure sizes fit in engine

DBW Actuator bracketry technical drawings on next page

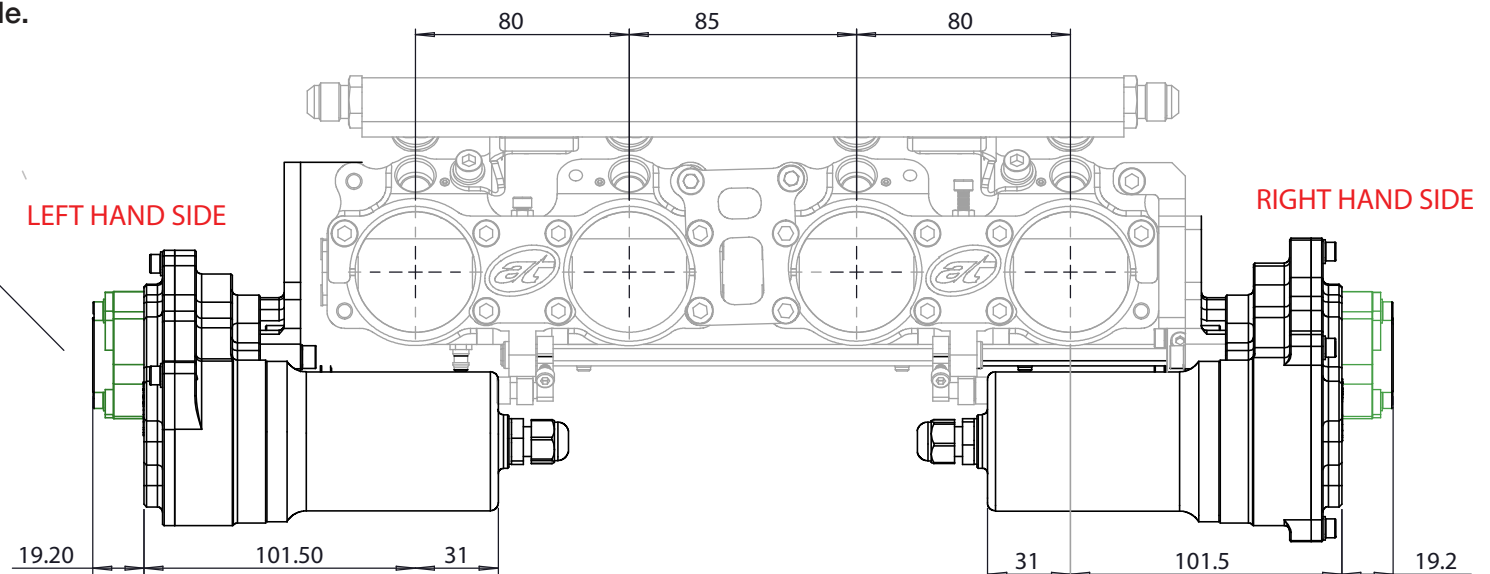

Right Hand Side Drive-By-Wire

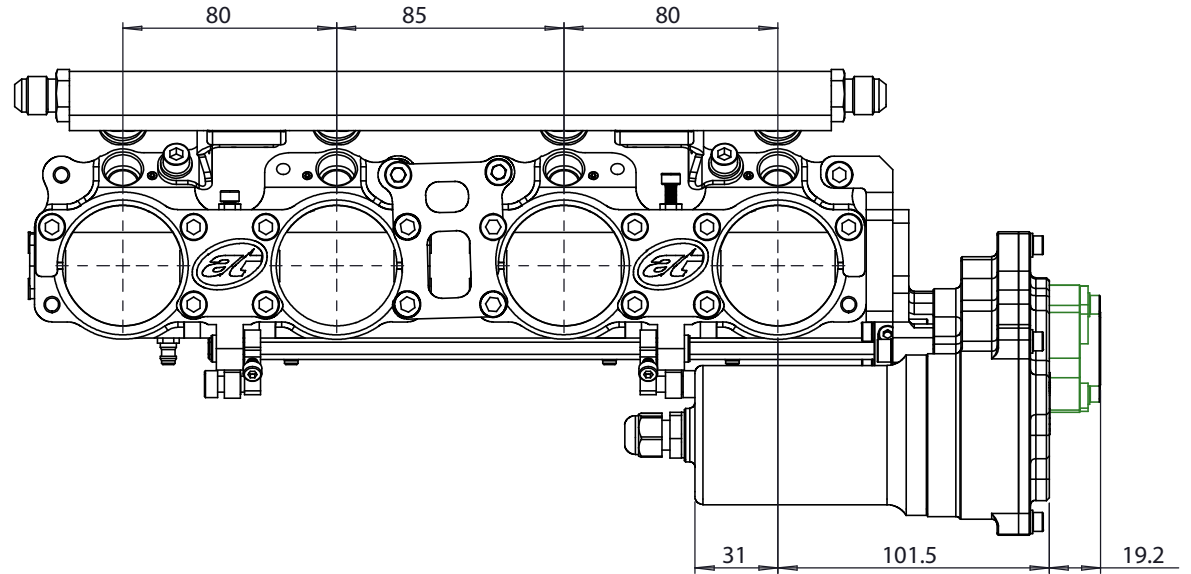

Optional Variohm XPK

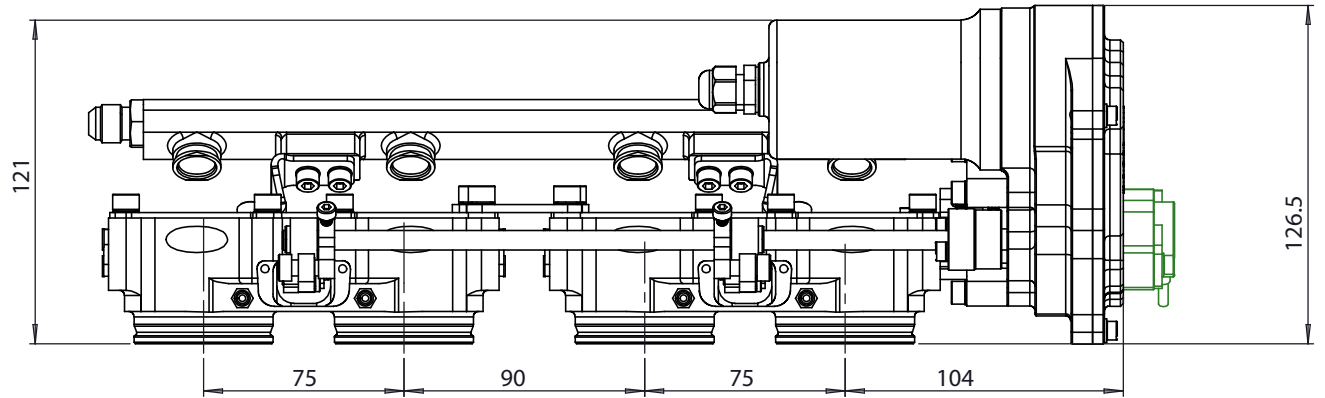
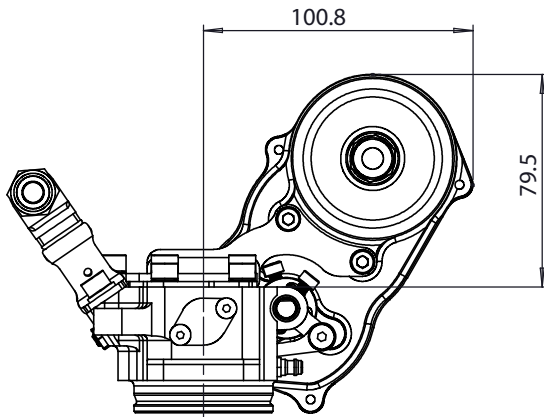

S-CAN 3D Ltd
Bunns Bank Ind Est
Attleborough NR17 1QD

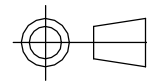

THIRD ANGLE PROJECTION

SCALE 1:2 WEIGHT 3.8 kg

DRAWN- S.HOW

DATE- 12/09/25

CHECKED - S.HOW

APPROVED - S.HOW

UNLESS OTHERWISE STATED:
DIMENSIONS IN MILLIMETRES
TOLERANCES: LINEAR ± 0.1 ANGULAR $\pm 0.5^\circ$
SURFACE FINISH $\sqrt{\text{V}}$ = $\sqrt{\text{V}}$
DRAWING STANDARDS TO ATQS 6003
DATE FORMAT: DD/MM/YY

THIS DESIGN IS THE PROPERTY OF
S-CAN 3D LTD AND MUST NOT BE
REPRODUCED OR COMMUNICATED
WITHOUT AUTHORITY

CAD PLOT
DO NOT
SCALE

MATERIAL

SEE COMPONENT PARTS

FINISH

SEE COMPONENT PARTS

DRAWING TITLE

ASSY - HOUSING - TWIN -
HAYABUSA - SINGLE
INJECTED - GEN 2 - 45MM

DRAWING NUMBER

--

Left Hand Side Drive-By-Wire

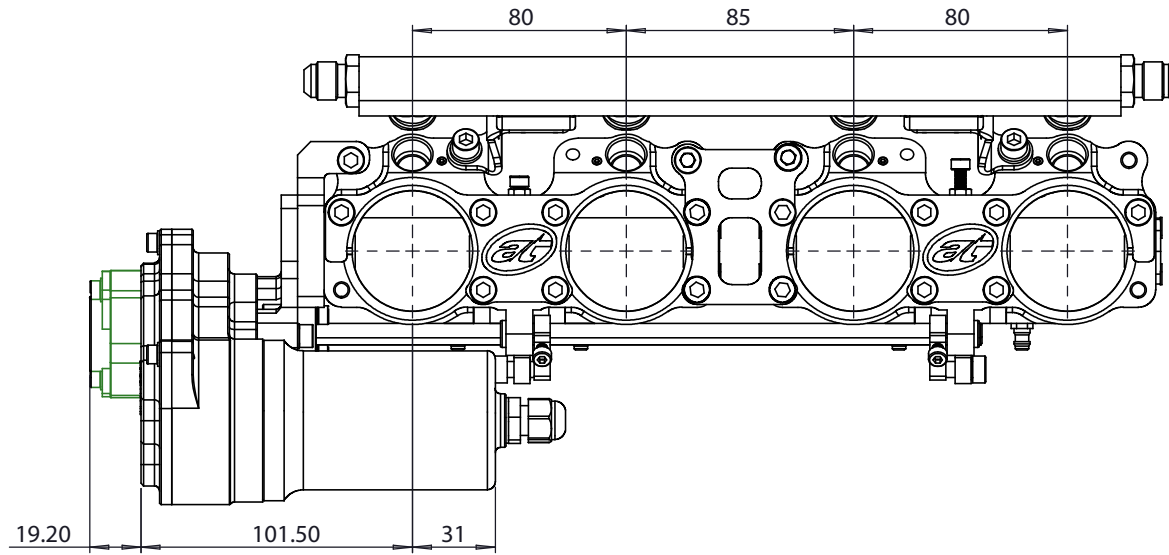

Optional Variohm XPK

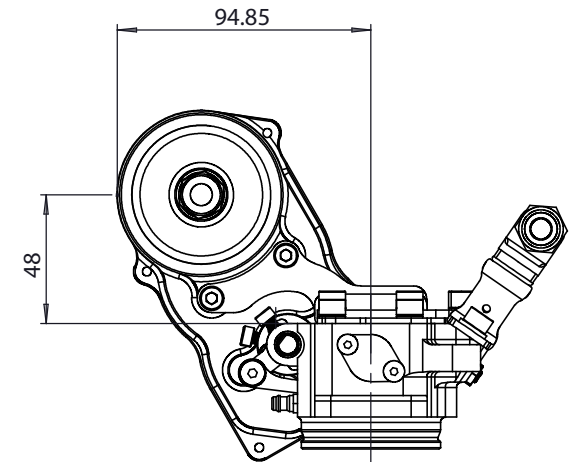
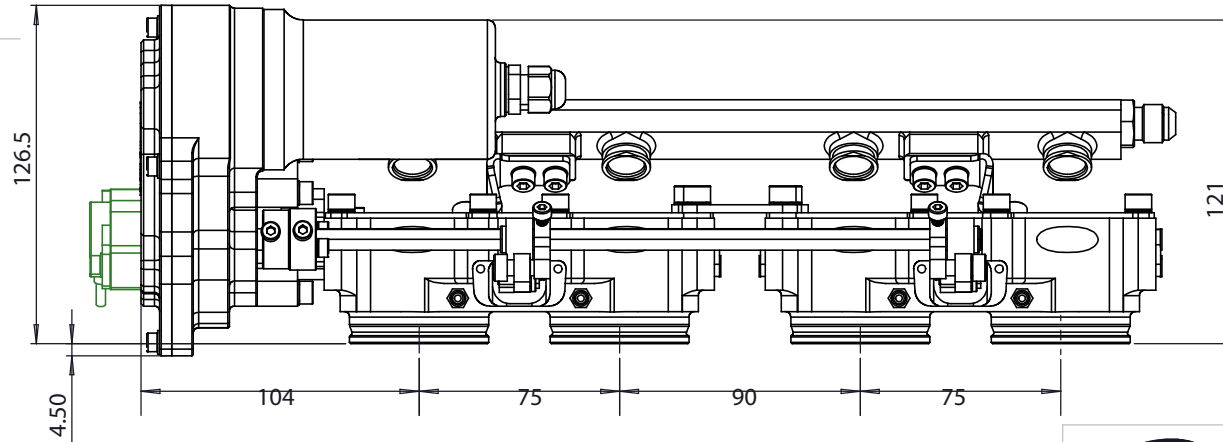

S-CAN 3D Ltd
Bunns Bank Ind Est
Attleborough NR17 1QD

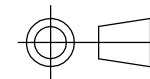

THIRD ANGLE PROJECTION

SCALE	WEIGHT
1:2	3.8 kg

DRAWN-	S.HOW
--------	-------

DATE-	12/09/25
-------	----------

CHECKED-	S.HOW
----------	-------

APPROVED-	S.HOW
-----------	-------

UNLESS OTHERWISE STATED:
DIMENSIONS IN MILLIMETRES
TOLERANCES: LINEAR ± 0.1 ANGULAR $\pm 0.5^\circ$
SURFACE FINISH $\sqrt{\text{V}}$
DRAWING STANDARDS TO ATQS 6003
DATE FORMAT: DD/MM/YY

THIS DESIGN IS THE PROPERTY OF
S-CAN 3D LTD AND MUST NOT BE
REPRODUCED OR COMMUNICATED
WITHOUT AUTHORITY

CAD PLOT
DO NOT
SCALE

MATERIAL

SEE COMPONENT PARTS

FINISH

SEE COMPONENT PARTS

DRAWING TITLE

ASSY - HOUSING - TWIN -
HAYABUSA - SINGLE
INJECTED - GEN 2 - 45MM

DRAWING NUMBER

--