

MEGAFLOW AIR FILTER SOLD SEPERATLY
 JC50/S65
 PART No. 102-108-00039

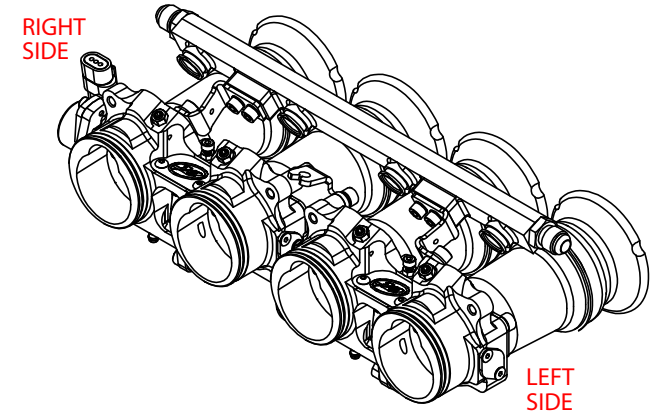

BRACKET FITTED IS SUITABLE
 FOR PICO FUEL INJECTORS

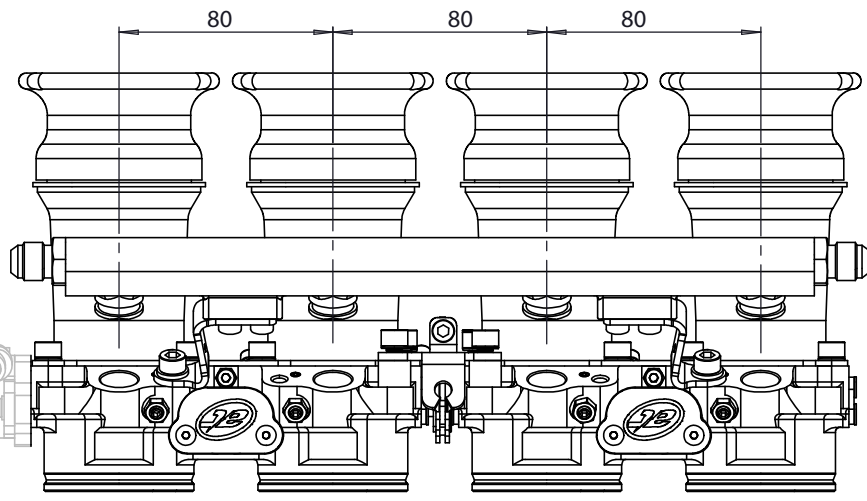
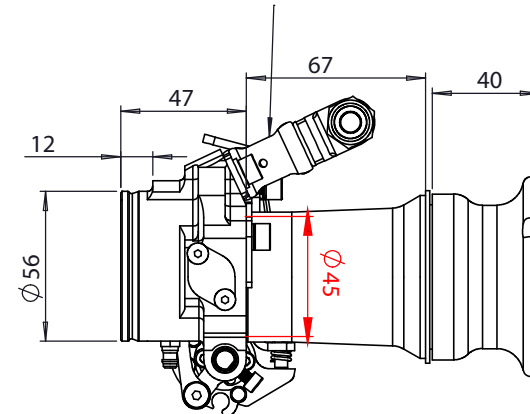

TPS OPTIONS AVAILABLE
 CAN BE FITTED BOTH ENDS

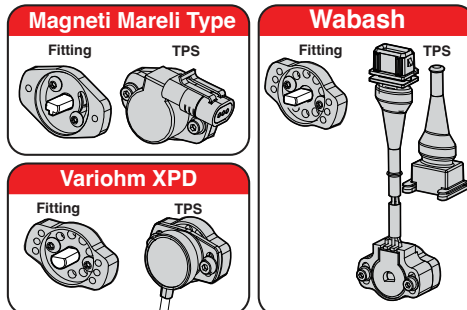

AN-6 MALE FITTINGS
 AT BOTH ENDS

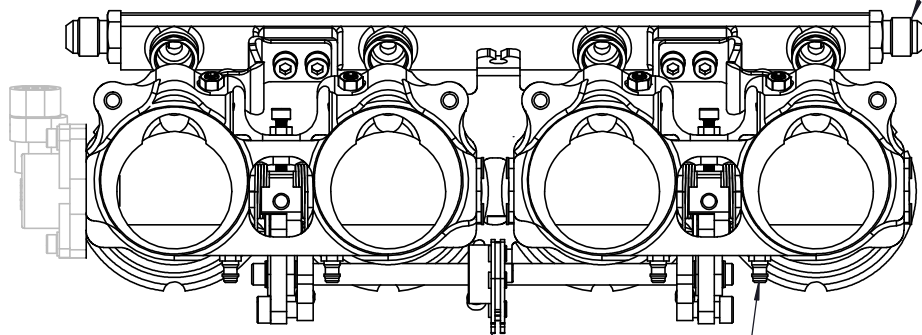

CENTRE PULL CABLE
 LINKAGE

4 X 6MM VACUUM
 TAKE OFF FITTINGS



S-CAN 3D Ltd
 Bunn's Bank Ind Est
 Attleborough NR17 1QD

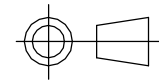

THIRD ANGLE PROJECTION

SCALE 1:2 WEIGHT 2.055 kg

DRAWN- S.HOW

DATE- 23/03/26

CHECKED- S.HOW

APPROVED- S.HOW

UNLESS OTHERWISE STATED:
 DIMENSIONS IN MILLIMETRES
 TOLERANCES: LINEAR ±0.1 ANGULAR ±0.5°
 SURFACE FINISH ✓ = √
 DRAWING STANDARDS TO ATQS 6003
 DATE FORMAT: DD/MM/YY

THIS DESIGN IS THE PROPERTY OF
 S-CAN 3D LTD AND MUST NOT BE
 REPRODUCED OR COMMUNICATED
 WITHOUT AUTHORITY

CAD PLOT
 DO NOT
 SCALE

MATERIAL

SEE COMPONENT PARTS

FINISH

SEE COMPONENT PARTS

DRAWING TITLE

ASSY - SUZUKI HAYABUSA
 GEN-1 - 45MM STD INJ - PRE-
 CONFIGURED - BIKE

DRAWING NUMBER

102-102-00671