

MEGAFLOW AIR FILTER SOLD SEPERATLY  
 JC50/S65  
 PART No. 102-108-00039

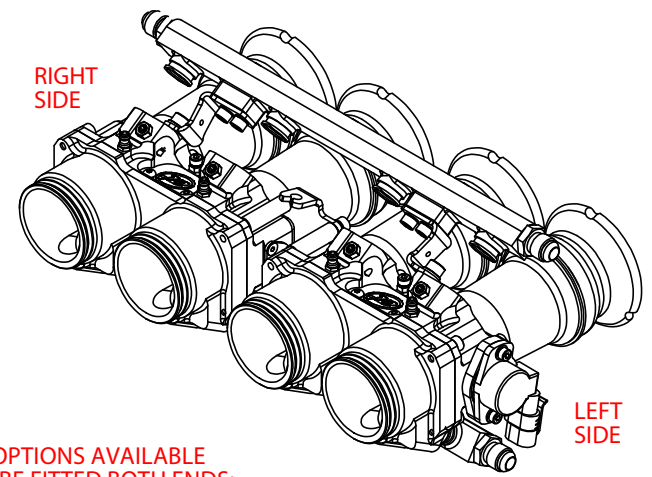

TPS OPTIONS AVAILABLE  
 CAN BE FITTED BOTH ENDS:

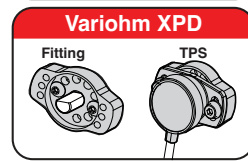
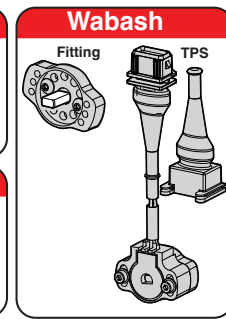
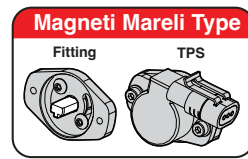

S-CAN 3D Ltd  
 Bunn's Bank Ind Est  
 Attleborough NR17 1QD

THIRD ANGLE PROJECTION

MATERIAL	SEE COMPONENT PARTS
FINISH	SEE COMPONENT PARTS
DRAWING TITLE	ASSY - SUZUKI HAYABUSA GEN-2 <b>-45MM 4 PICO + 4OEM INJ -</b> PRE-CONFIGURED - BIKE
DRAWING NUMBER	102-102-00674

UNLESS OTHERWISE STATED:  
 DIMENSIONS IN MILLIMETRES  
 TOLERANCES: LINEAR ±0.1 ANGULAR ±0.5°  
 SURFACE FINISH √ = √  
 DRAWING STANDARDS TO ATQS 6003  
 DATE FORMAT: DD/MM/YY

THIS DESIGN IS THE PROPERTY OF  
 S-CAN 3D LTD AND MUST NOT BE  
 REPRODUCED OR COMMUNICATED  
 WITHOUT AUTHORITY

CAD PLOT  
 DO NOT  
 SCALE

WEIGHT	2.954 kg
DRAWN -	S.HOW
DATE -	23/03/26
CHECKED -	S.HOW
APPROVED -	S.HOW